



**M400**

CONT 375 kVA



### THREE-PHASE SYNCHRONOUS GENERATOR

Datasheet for 4 poles -50Hz @ 1500rpm/ 60Hz @ 1800rpm

Ambient Temperature	40 °C	Method of Cooling	Air cooling	
Temperature Rise	125 °C	Direction of Rotation	Clockwise	
Insulation Class	H	Maximum Over-speed	2250r/min	
Power Factor	0.8	Degree of Protection / Enclosure	IP23	
Excitation	Brushless	Altitude	1000m	
Winding Pitch	2/3	Stator winding	DLL	
Pole	4	Number of Terminal	12	
Duty	S1- Continuous	Rotor	With damping cage	
Waveform	TIF<50		THF<2%	
Waveform distortion	BS EN 61000-6-2&BS EN 61000-6-4,VDE 0875G,VDE0874N			
Radio interference	Noload<1.5%,Non-distorting balanced linear load<5%			
AVR MODEL AVR	Standard	Selection		PMG
	AS440	KRS440		MX341B MX321
Voltage Regulation - in steady state condition	±1.0	±1.0	±0.5	±0.5
Short Circuit Current Capacity	Control does not sustain a short circuit current			1650A

#### Electrical Characteristic

Frequency	Hz	50				60			
Voltage ( series star ) <b>Y</b>	V	380/220	400/231	415/240	440/254	416/240	440/254	460/266	480/277
Voltage ( parallel star ) <b>YY</b>	V	190/110	200/115	208/120	220/127	208/120	220/127	230/133	240/138
Voltage ( series delta ) <b>Δ</b>	V	220	230	240	254	240	254	266	277
Rated power at Class H (125 °C) temperature rise	kVA	375	375	375	375	420	435	460	460
	kW	300.0	300.0	300.0	300.0	336.0	348.0	368.0	368.0
Efficiency at Class H (P.F.=0.8)	4/4%	93.2	93.3	93.6	93.8	93.3	93.4	93.4	93.7
	3/4%	94.2	94.3	94.3	94.3	94.3	94.3	94.4	94.4
	2/4%	94.5	94.4	94.3	94.2	94.4	94.4	94.4	0.3
Efficiency at Class H (P.F.=1.0)	4/4%	94.6	94.8	95	95.1	94.8	94.8	94.9	95
	3/4%	95.5	95.6	95.6	95.7	95.5	95.6	95.6	95.7
	2/4%	95.7	95.7	95.7	95.6	95.7	95.7	95.7	95.7

#### Reactances (%) at Class H

Direct axis synchronous reactance unsaturated	Xd	2.74	2.46	2.29	2.05	3.29	3.1	2.98	2.76
Direct axis transient reactance saturated	X'd	0.18	0.16	0.15	0.13	0.18	0.17	0.16	0.15
Direct axis subtransient reactance saturated	X''d	0.13	0.12	0.11	0.1	0.13	0.12	0.12	0.11
Quadrature axis synchronous reactance unsaturated	Xq	2.37	2.15	1.98	1.77	2.95	2.76	2.64	2.41
Quadrature axis subtransient reactance saturated	X''q	0.31	0.28	0.26	0.23	0.43	0.41	0.39	0.35
Leakage reactance	X1	0.06	0.05	0.05	0.04	0.07	0.07	0.06	0.06
Negative sequence reactance saturated	X2	0.23	0.2	0.19	0.17	0.29	0.27	0.26	0.24
Zero sequence reactance unsaturated	X0	0.08	0.08	0.07	0.06	0.1	0.09	0.09	0.08
Short-circuit ratio	Kcc	0.3650	0.4065	0.4367	0.4878	0.3040	0.3226	0.3356	0.3623

Short-circuit transient time constant (sec.)	T'd	0.08							
Subtransient time constant (sec.)	T''d	0.018							
Open circuit time constant (sec.)	T'do	1.65							
Armature time constant (sec.)	Ta	0.018							
Stator Winding Resistance (20°C)	ohm	0.00766							
Rotor Winding Resistance (20°C)	ohm	1.26							
Exciter Stator Resistance (20°C)	ohm	18							
Exciter Rotor Phase resistance	ohm	0.068							
No load excitation current	io (A)	0.5	0.52	0.6	0.6	0.5	0.51	0.6	0.6
Full load excitation current	ic(A)	2.2	2.2	2.3	2.3	2.2	2.2	2.3	2.3
Cooling air requirement	m <sup>3</sup> /sec	0.8m <sup>3</sup> /s 1700cfm				0.99m <sup>3</sup> /s 2100cfm			

#### Mechanical Characteristic

Configuration	Single Bearing	Double Bearing
Type of Construction	B2-SAE	IM B34
Total Weight - kgs	1088	1068
Weight wound stator - kgs	502	502
Weight wound rotor - kgs	432.4	410
Inertia (J) [kgm <sup>2</sup> ]	4.998kgm <sup>2</sup>	4.799kgm <sup>2</sup>
Drive end bearing / Lubrication		BALL.6317-2RS(ISO)
Non-drive end bearing / Lubrication	BALL.6314-2RS(ISO)	BALL.6314-2RS(ISO)
Packing crate size (cm)	133X70X104	145X70X104

# Winding 311 / 0.8 Power Factor

## RATINGS

Class - Temp Rise		Cont. F - 105/40° C				Cont. H - 125/40° C				Standby - 150/40° C				Standby - 163/27° C			
50 Hz	Series Star (V)	380	400	415	440	380	400	415	440	380	400	415	440	380	400	415	440
	Parallel Star (V)	190	200	208	220	190	200	208	220	190	200	208	220	190	200	208	220
	Series Delta (V)	220	230	240	254	220	230	240	254	220	230	240	254	220	230	240	254
	kVA	345	345	345	345	375	375	375	375	401.3	401.3	401.3	401.3	412.5	412.5	412.5	412.5
	kW	276	276	276	276	300	300	300	300	321	321	321	321	330	330	330	330
	Efficiency (%)	93.5	93.8	93.9	94	93.2	93.4	93.6	93.8	92.9	93	93.2	93.5	92.8	92.8	93.1	93.4
	kW Input	295	294	294	294	322	321	321	320	346	345	344	343	356	356	354	353
60 Hz	Series Star (V)	416	440	460	480	416	440	460	480	416	440	460	480	416	440	460	480
	Parallel Star (V)	208	220	230	240	208	220	230	240	208	220	230	240	208	220	230	240
	Series Delta (V)	240	254	266	277	240	254	266	277	240	254	266	277	240	254	266	277
	kVA	386.4	400.2	423.2	423.2	420	435	460	460	453.6	469.8	496.8	496.8	462	478.5	506	506
	kW	309.1	320.2	338.6	338.6	336	348	368	368	362.9	375.8	397.4	397.4	369.6	382.8	404.8	404.8
	Efficiency (%)	93.7	93.8	93.8	94	93.4	93.4	93.5	93.7	93.1	93.1	93.1	93.4	92.9	92.9	93	93.2
	kW Input	330	341	361	360	360	373	394	393	390	404	427	426	398	412	435	434

## DIMENSIONS

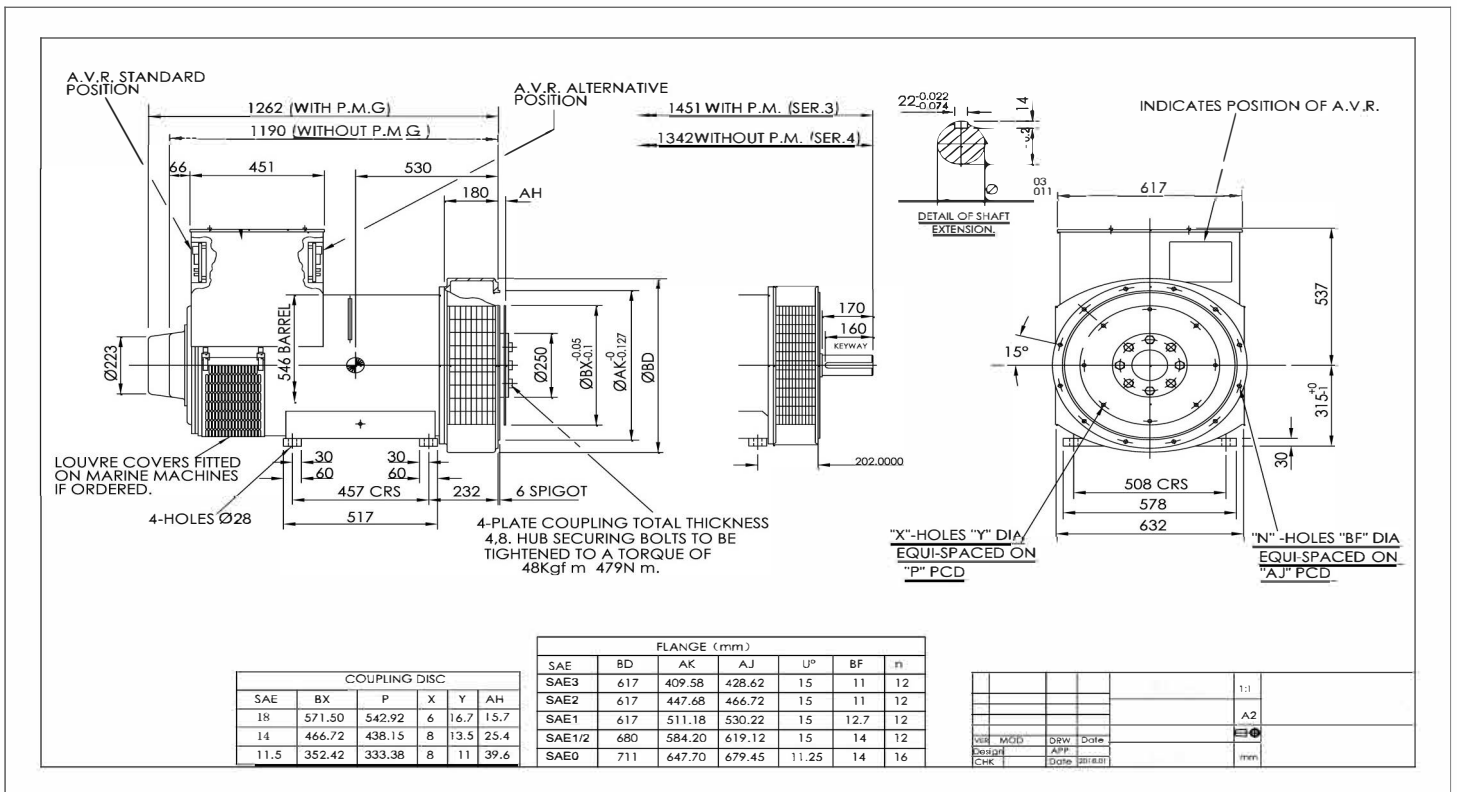

**50  
Hz**

**Winding 311  
THREE PHASE EFFICIENCY CURVES**

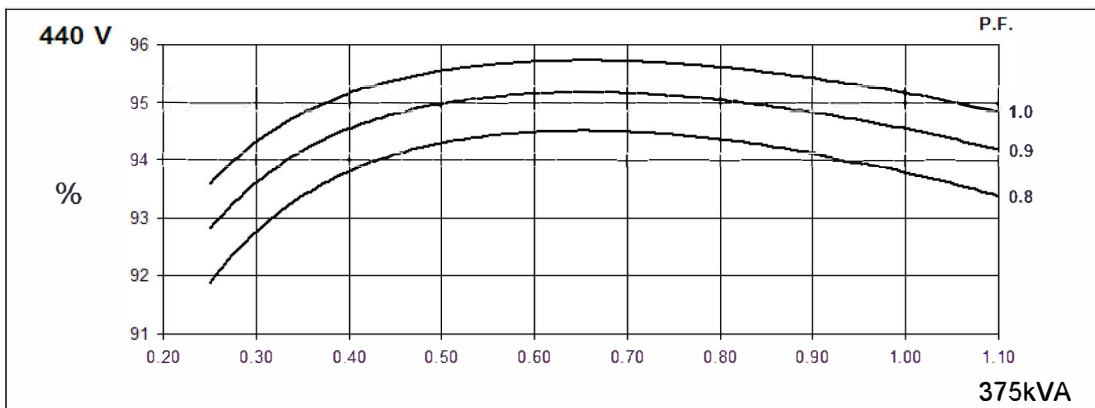
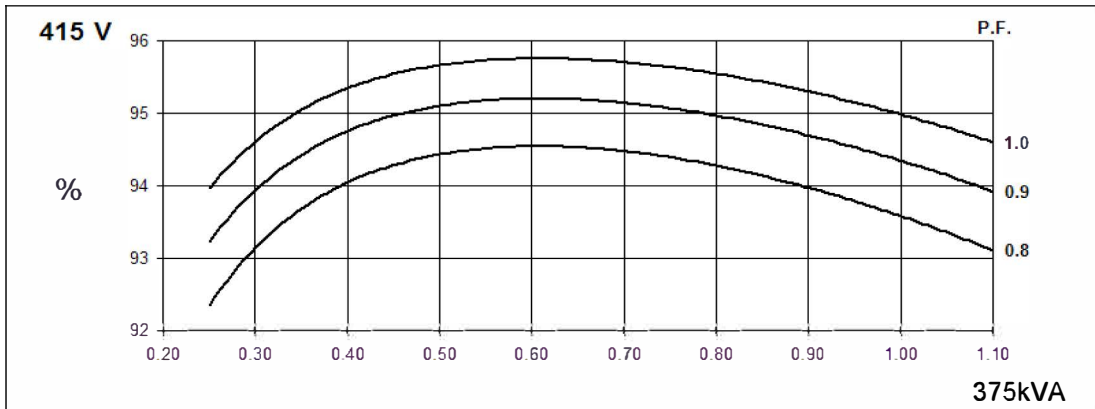
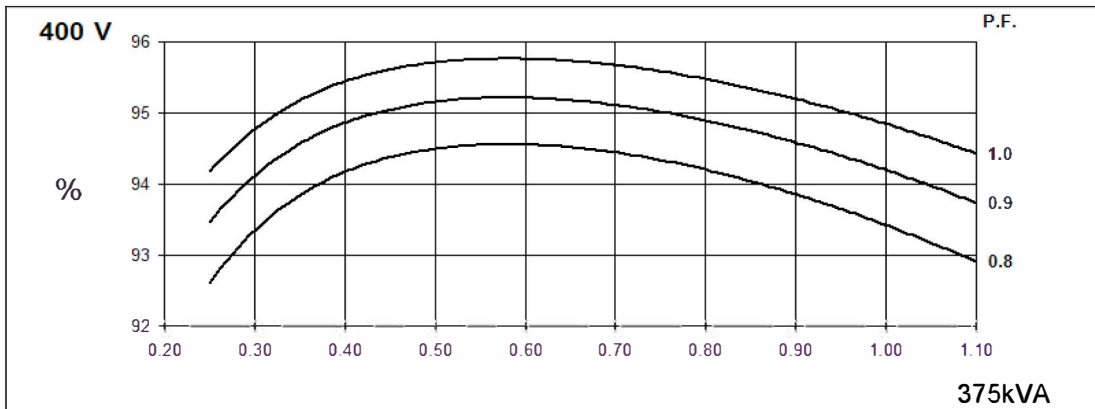
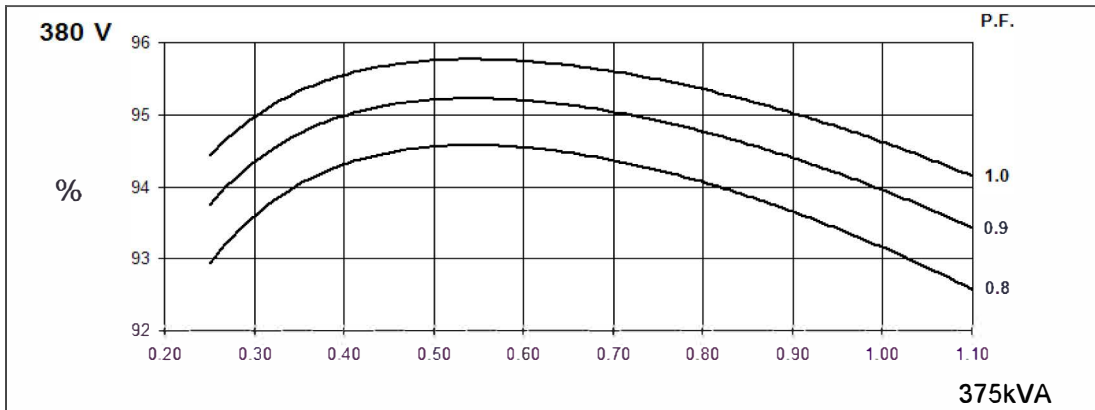

**60  
Hz**

**Winding 311  
THREE PHASE EFFICIENCY CURVES**

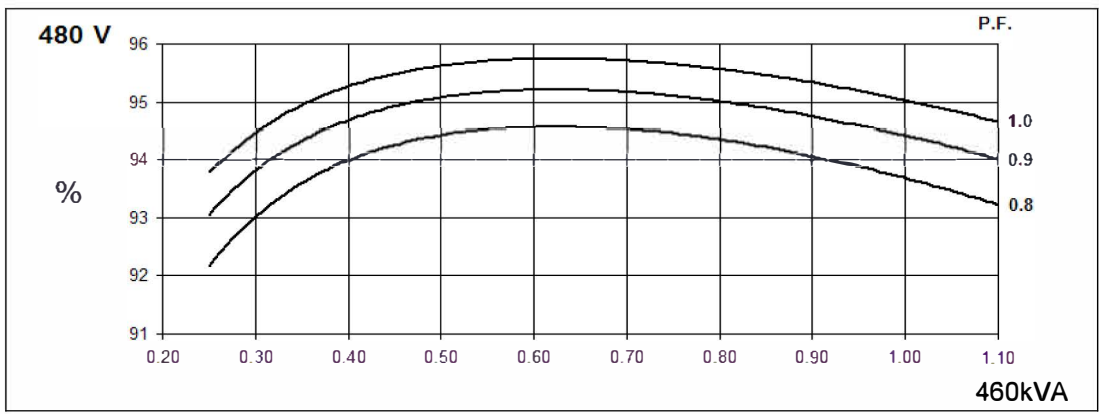
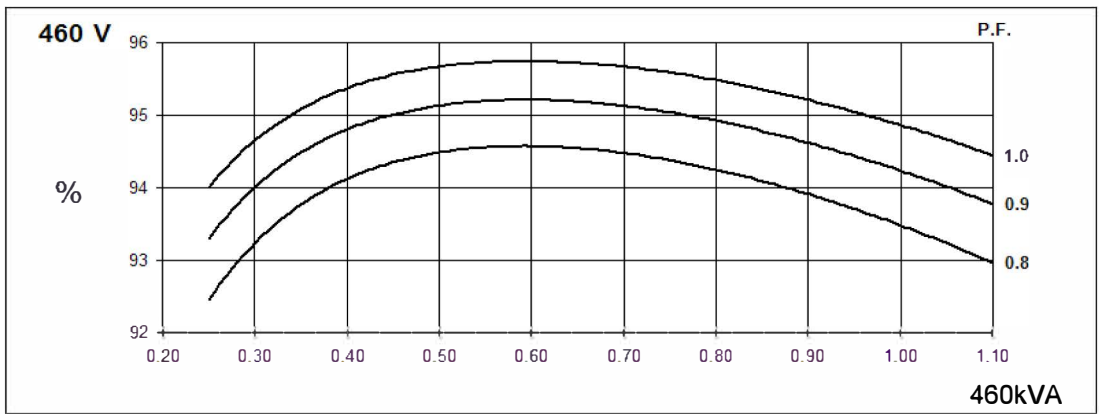
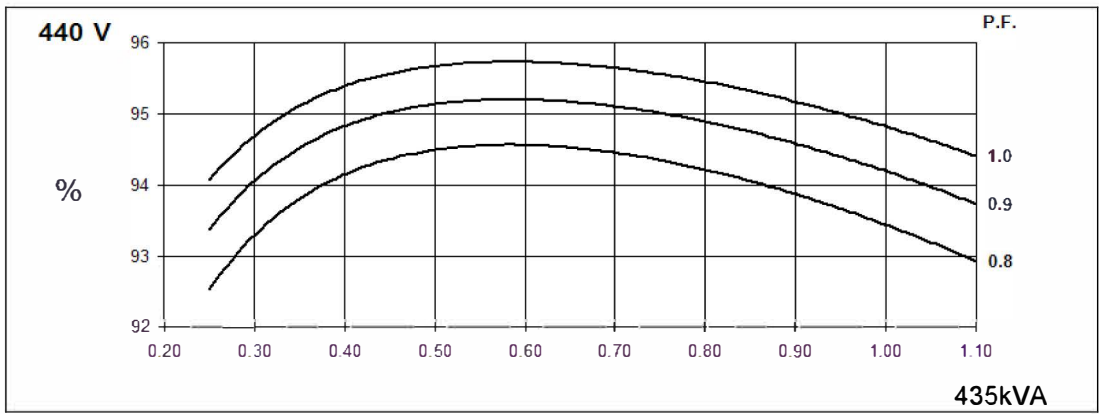
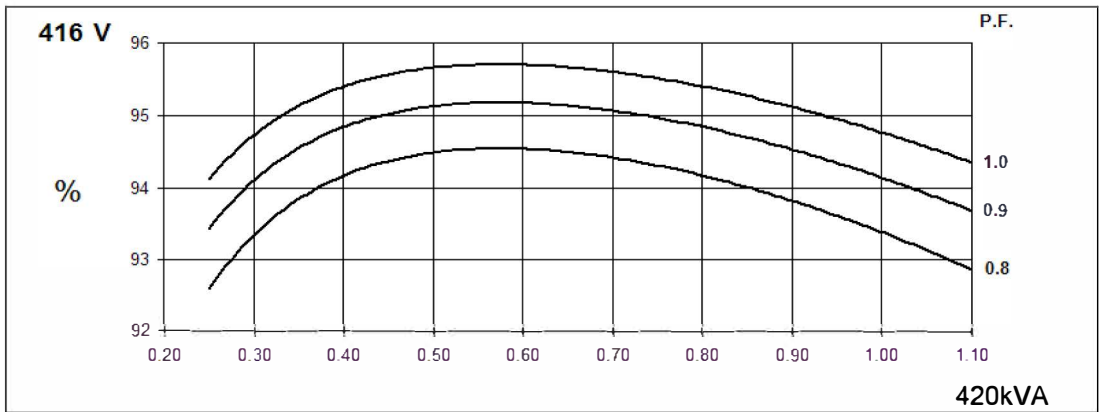

**Three-phase Short Circuit Decrement Curve. No-load Excitation at Rated Speed  
Based on star (wye) connection.**

**50  
Hz**

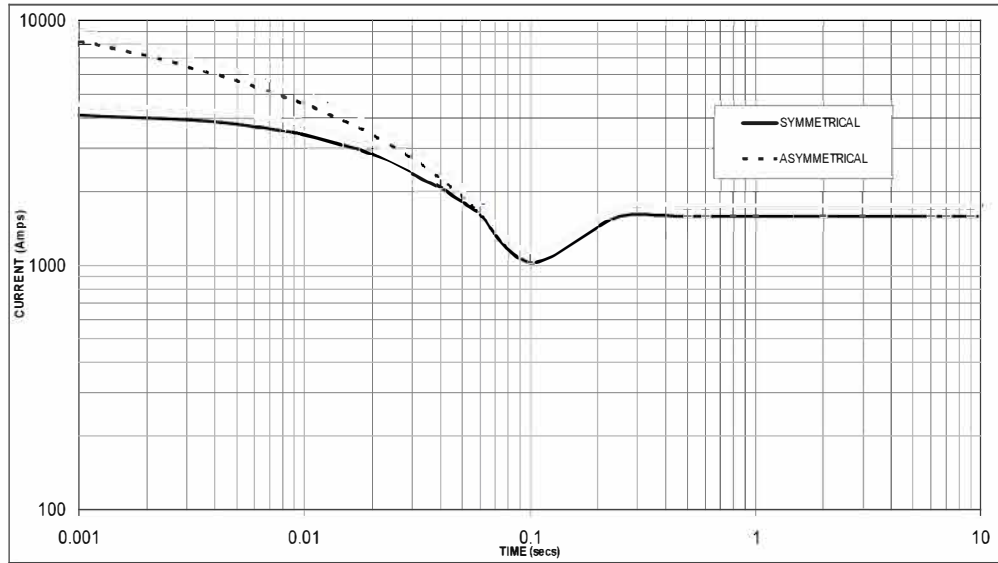

Sustained Short Circuit = 1,650 Amps

**60  
Hz**

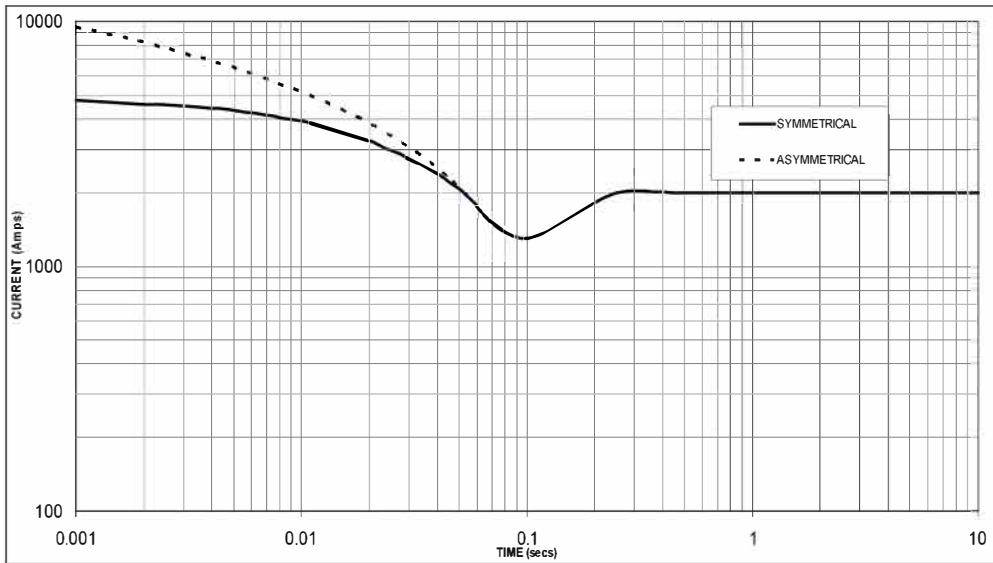

Sustained Short Circuit = 2,000 Amps

**Note 1**

The following multiplication factors should be used to adjust the values from curve between time 0.001 seconds and the minimum current point in respect of nominal operating voltage :

50Hz		60Hz	
Voltage	Factor	Voltage	Factor
380v	X 1.00	416v	X 1.00
400v	X 1.05	440v	X 1.06
415v	X 1.09	460v	X 1.10
440v	X 1.16	480v	X 1.15

The sustained current value is constant irrespective of voltage level

**Note 2**

The following multiplication factor should be used to convert the values calculated in accordance with NOTE 1 to those applicable to the various types of short circuit :

	3-phase	2-phase L-L	1-phase L-N
Instantaneous	x 1.00	x 0.87	x 1.30
Minimum	x 1.00	x 1.80	x 3.20
Sustained	x 1.00	x 1.50	x 2.50
Max. sustained duration	10 sec.	5 sec.	2 sec.

All other times are unchanged

**Note 3**

Curves are drawn for Star (Wye) connected machines. For other connection the following multipliers should be applied to current values as shown :

Parallel Star = Curve current value X 2

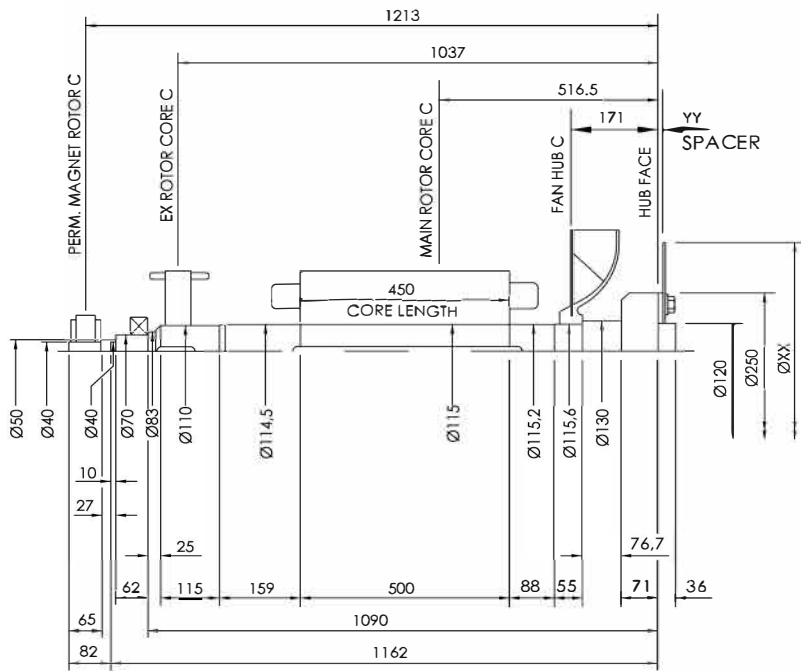

COMPONENT	Wt kg	J kgm <sup>2</sup>
EX. ROTOR	31,290	0,5100
MAIN ROTOR	273	3,878
FAN	9,910	0,2630
SHAFT	94,53	0,1571
HUB	18,507	0,1779
TOTAL	427,237	4,986
PERM. MAG.	5,215	0,0122
TOTAL	432,452	4,998

COUPLING SAE No	COUPLING DIMEN's		COUPLING ASSEMBLY WEIGHT kg	COUPLING DISC J kgm <sup>2</sup>
	XX	YY		
11,5	352	23,8	12,08	0,055
14	467	9,5	11,66	0,172
18	572	0,0	12,07	0,386

VER	MOD	DRW	Date	E+
Design		APP		
CHK		Date	2018.01	
				mm

