



M730

CONT 670 kVA



THREE-PHASE SYNCHRONOUS GENERATOR

Datasheet for 4 poles -50Hz @ 1500rpm/ 60Hz @ 1800rpm

Ambient Temperature	40 °C	Method of Cooling	Air cooling	
Temperature Rise	125 °C	Direction of Rotation	Clockwise	
Insulation Class	H	Maximum Over-speed	2250r/min	
Power Factor	0.8	Degree of Protection / Enclosure	IP23	
Excitation	Brushless	Altitude	1000m	
Winding Pitch	2/3	Stator winding	DLL	
Pole	4	Number of Terminal	12	
Duty	S1- Continuous	Rotor	With damping cage	
Waveform	TIF<50		THF<2%	
Waveform distortion	BS EN 61000-6-2&BS EN 61000-6-4,VDE 0875G,VDE0874N			
Radio interference	Noload<1.5%,Non-distorting balanced linear load<5%			
AVR MODEL AVR	Standard	Selection		PMG
	AS440	KRS440		MX341B MX321
Voltage Regulation - in steady state condition	±1.0	±1.0	±0.5	±0.5
Short Circuit Current Capacity	Control does not sustain a short circuit current			2900A

Electrical Characteristic

Frequency	Hz	50				60			
Voltage (series star) Y	V	380/220	400/231	415/240	440/254	416/240	440/254	460/266	480/277
Voltage (parallel star) YY	V	190/110	200/115	208/120	220/127	208/120	220/127	230/133	240/138
Voltage (series delta) Δ	V	220	230	240	254	240	254	266	277
Rated power at Class H (125 °C) temperature rise	kVA	670	670	670	650	738	775	800	825
	kW	536.0	536.0	536.0	520.0	590.4	620.0	640.0	660.0
Efficiency at Class H (P.F.=0.8)	4/4%	94.8	95	95	95.2	95	95	95	95.1
	3/4%	95.4	95.5	95.5	95.5	95.4	95.4	95.5	95.5
	2/4%	95.5	95.3	95.3	95.1	95.2	95.2	95.2	95.2
Efficiency at Class H (P.F.=1.0)	4/4%	95.9	96.1	96.1	96.2	96	96	96.1	96.1
	3/4%	96.4	96.5	96.6	96.5	96.4	96.5	96.5	96.5
	2/4%	96.5	96.4	96.3	96.2	96.2	96.2	96.2	96.2

Reactances (%) at Class H

Direct axis synchronous reactance unsaturated	Xd	2.9	2.62	2.43	2.1	3.33	3.13	2.95	2.8
Direct axis transient reactance saturated	X'd	0.16	0.14	0.13	0.11	0.16	0.15	0.14	0.13
Direct axis subtransient reactance saturated	X''d	0.11	0.1	0.09	0.08	0.11	0.1	0.1	0.09
Quadrature axis synchronous reactance unsaturated	Xq	2.42	2.19	2.03	1.75	2.66	2.5	2.36	2.23
Quadrature axis subtransient reactance saturated	X''q	0.25	0.23	0.21	0.18	0.31	0.29	0.27	0.26
Leakage reactance	X1	0.05	0.04	0.04	0.03	0.05	0.05	0.04	0.04
Negative sequence reactance saturated	X2	0.18	0.16	0.15	0.13	0.21	0.2	0.19	0.18
Zero sequence reactance unsaturated	X0	0.08	0.08	0.07	0.06	0.09	0.08	0.08	0.08
Short-circuit ratio	Kcc	0.3448	0.3817	0.4115	0.4762	0.3003	0.3195	0.3390	0.3571

Short-circuit transient time constant (sec.)	T'd	0.08							
Subtransient time constant (sec.)	T''d	0.012							
Open circuit time constant (sec.)	T'do	2.5							
Armature time constant (sec.)	Ta	0.019							
Stator Winding Resistance (20°C)	ohm	0.0037							
Rotor Winding Resistance (20°C)	ohm	2.14							
Exciter Stator Resistance (20°C)	ohm	17							
Exciter Rotor Phase resistance	ohm	0.092							
No load excitation current	io (A)	0.59	0.6	0.63	0.64	0.59	0.6	0.61	0.64
Full load excitation current	ic(A)	2.4	2.4	2.5	2.5	2.4	2.4	2.5	2.5
Cooling air requirement	m ³ /sec	1.035m3/s 2202cfm				1.312m3/s 2780cfm			

Mechanical Characteristic

Configuration	Single Bearing	Double Bearing
Type of Construction	B2-SAE	IM B34
Total Weight - kgs	1632	1612
Weight wound stator - kgs	795	795
Weight wound rotor - kgs	684	655
Inertia (J) [kgm ²]	10.033kgm ²	9.7551kgm ²
Drive end bearing / Lubrication		BALL.6220-2RS(ISO)
Non-drive end bearing / Lubrication	BALL.6314-2RS(ISO)	BALL.6314-2RS(ISO)
Packing crate size (cm)	149X80X115	156X80X115

Winding 311 0.8 Power Factor

RATINGS

Class - Temp Rise		Cont. F - 105/40°C				Cont. H - 125/40°C				Standby - 150/40°C				Standby - 163/27°C			
50 Hz	Series Star (V)	380	400	415	440	380	400	415	440	380	400	415	440	380	400	415	440
	Parallel Star (V)	190	200	208	220	190	200	208	220	190	200	208	220	190	200	208	220
	Series Delta (V)	220	230	240	254	220	230	240	254	220	230	240	254	220	230	240	254
	kVA	620	620	620	600	670	670	670	650	710	710	710	690	738	738	738	715
	kW	496	496	496	480	536	536	536	520	568	568	568	552	590	590	590	572
	Efficiency (%)	95.0	95.2	95.3	95.4	94.8	95.0	95.1	95.3	94.6	94.8	94.9	95.1	94.4	94.6	94.8	95.1
	kW Input	522	521	520	503	565	564	564	546	600	599	599	580	625	624	623	601
60 Hz	Series Star (V)	416	440	460	480	416	440	460	480	416	440	460	480	416	440	460	480
	Parallel Star (V)	208	220	230	240	208	220	230	240	208	220	230	240	208	220	230	240
	Delta (V)	240	254	266	277	240	254	266	277	240	254	266	277	240	254	266	277
	kVA	688	719	731	750	738	775	800	825	781	819	848	875	806	844	878	906
	kW	550	575	585	600	590	620	640	660	625	655	678	700	645	675	702	725
	Efficiency (%)	95.1	95.2	95.3	95.3	95.0	95.0	95.1	95.1	94.8	94.9	94.9	95.0	94.7	94.8	94.8	94.9
	kW Input	579	604	614	630	621	653	673	694	659	690	715	737	681	712	741	764

DIMENSIONS

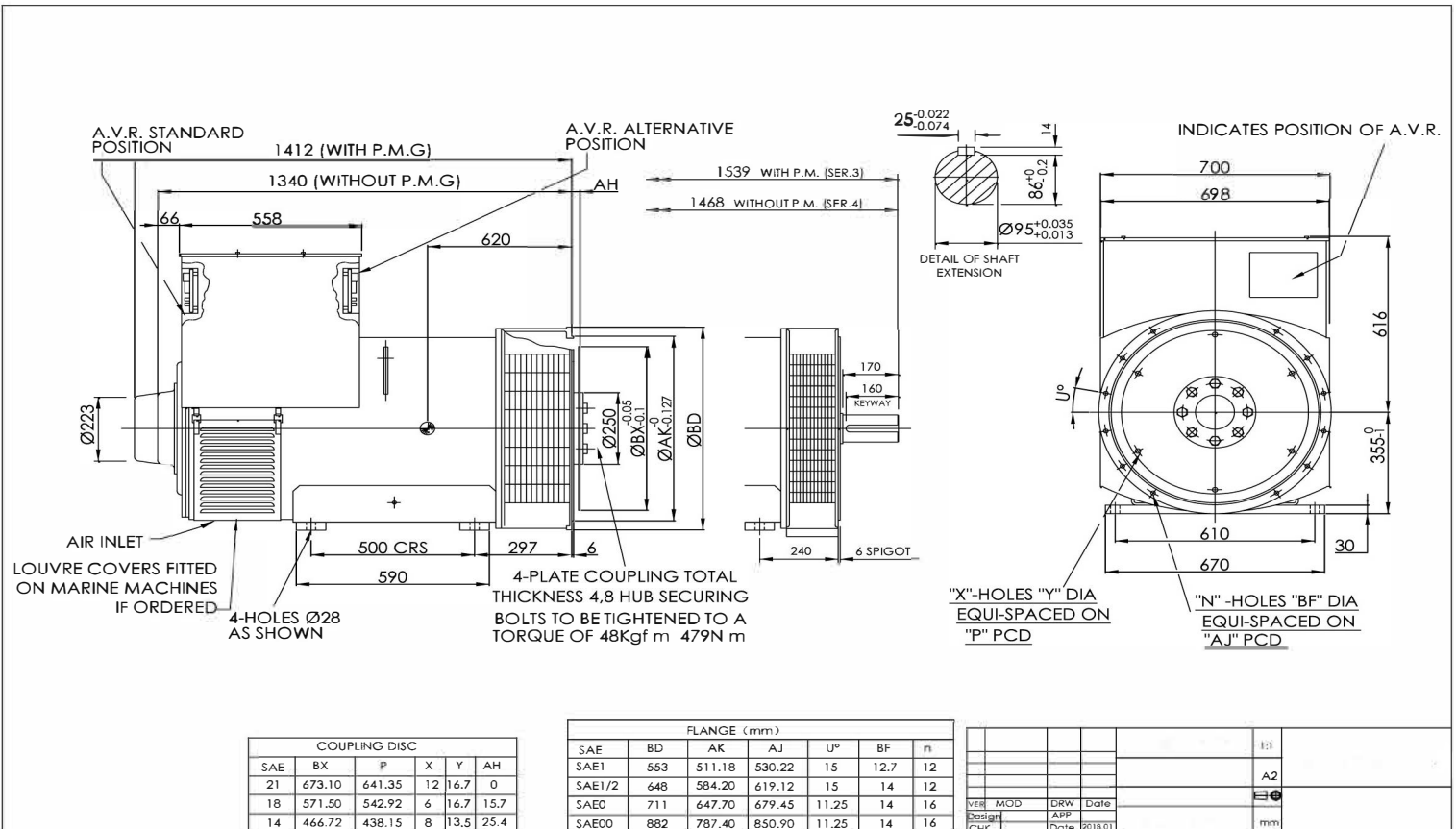

50
Hz

Winding 311

THREE PHASE EFFICIENCY CURVES

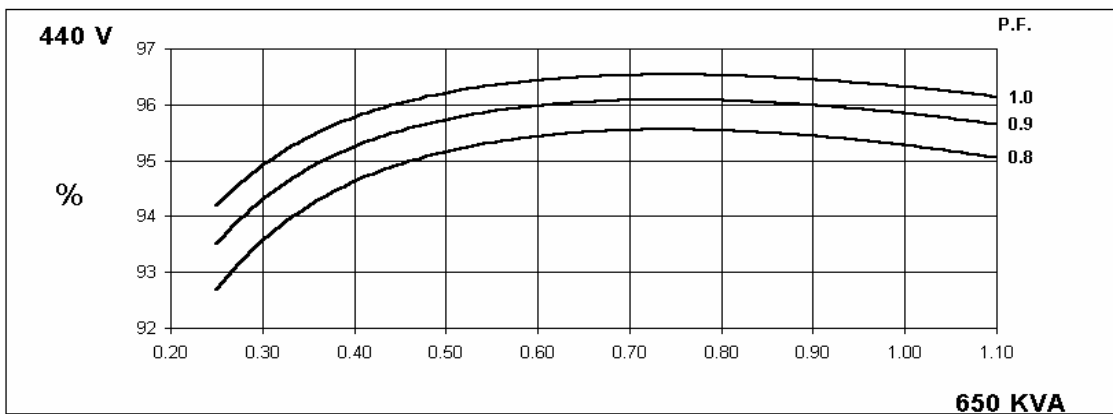
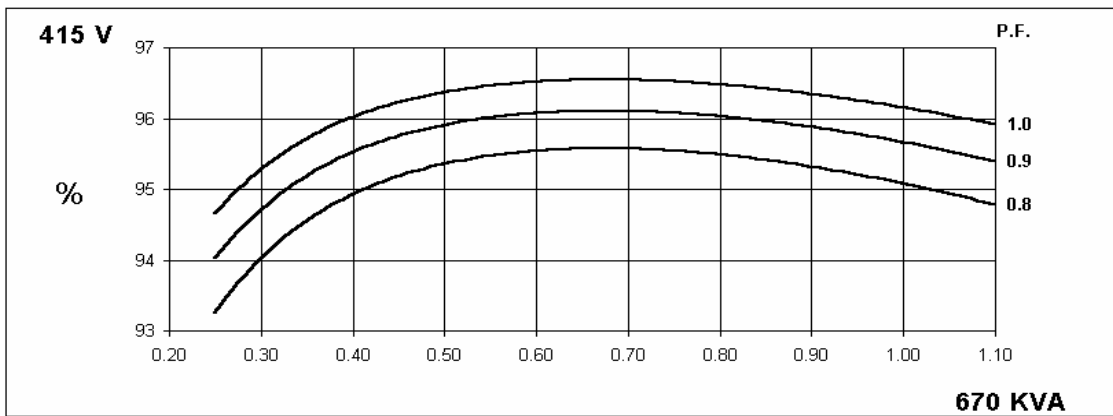
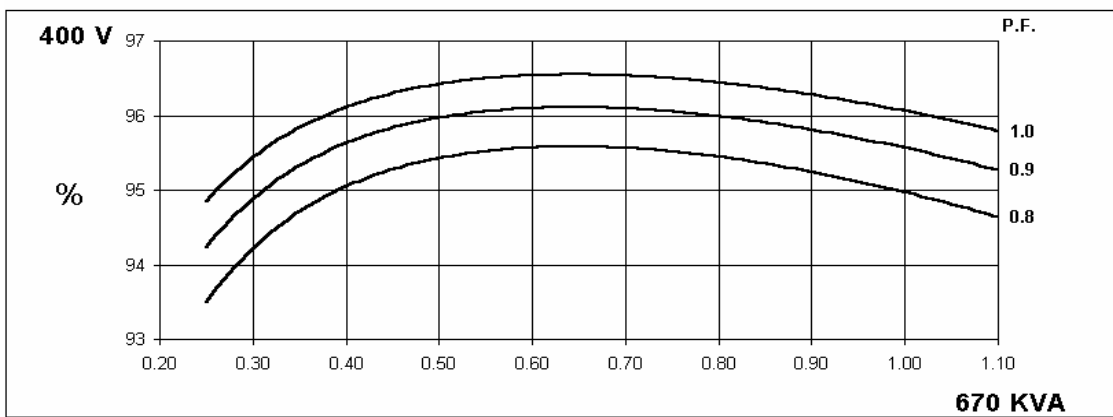
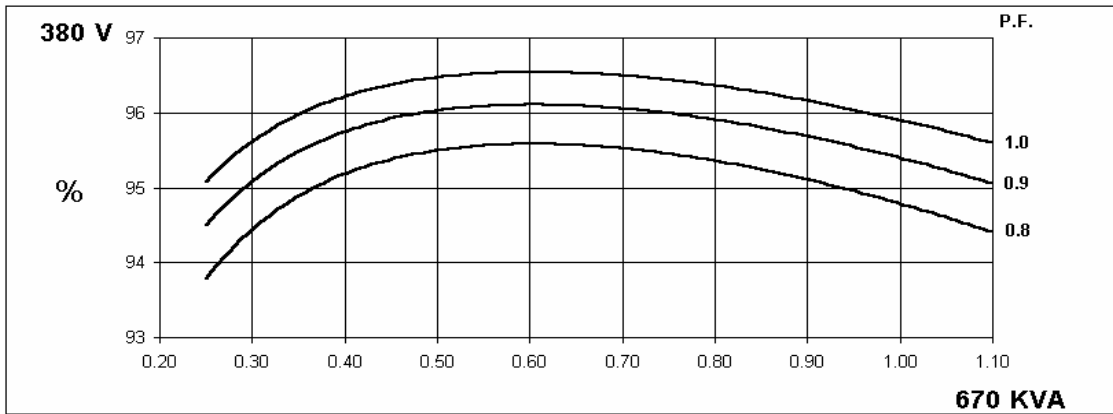

60
Hz

Winding 311

THREE PHASE EFFICIENCY CURVES

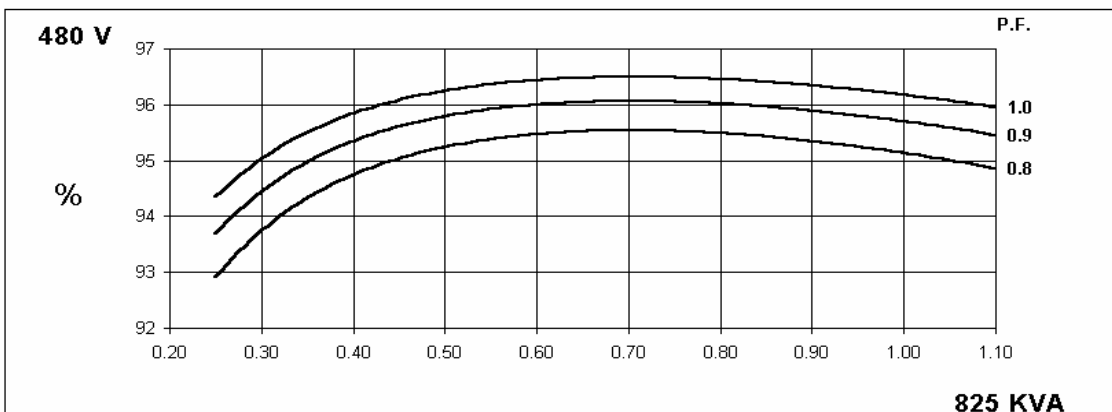
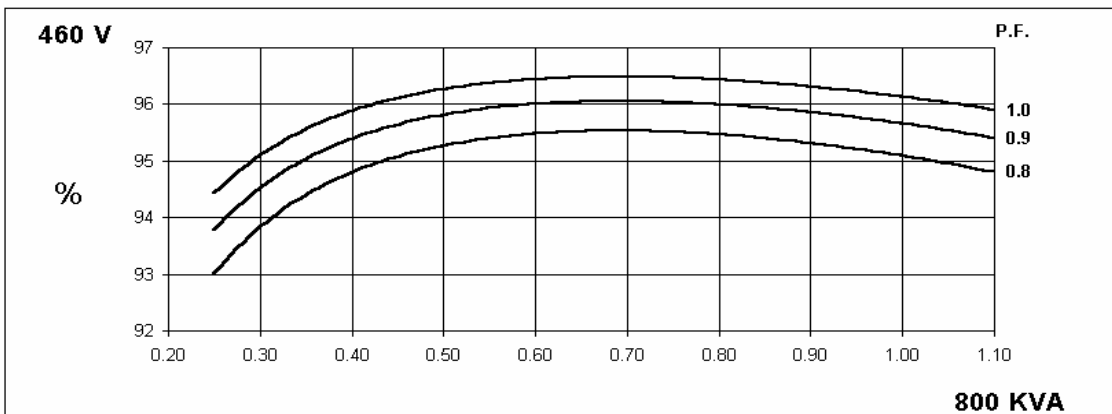
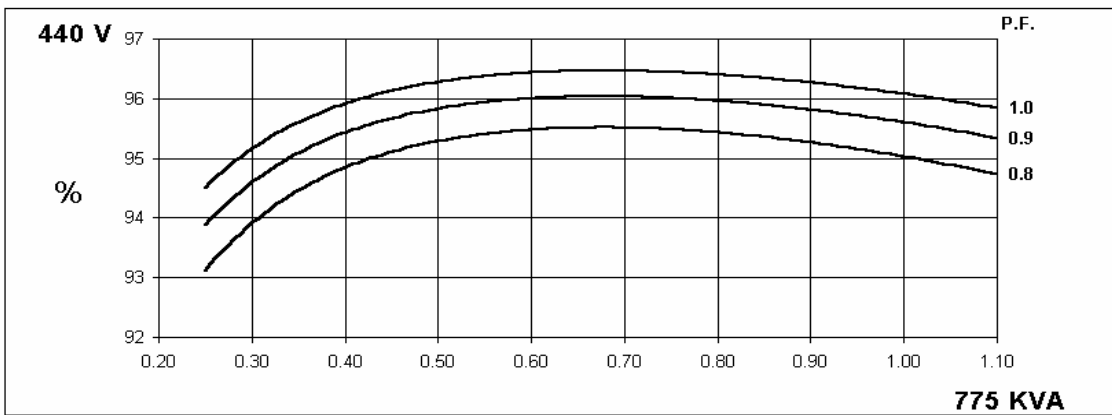
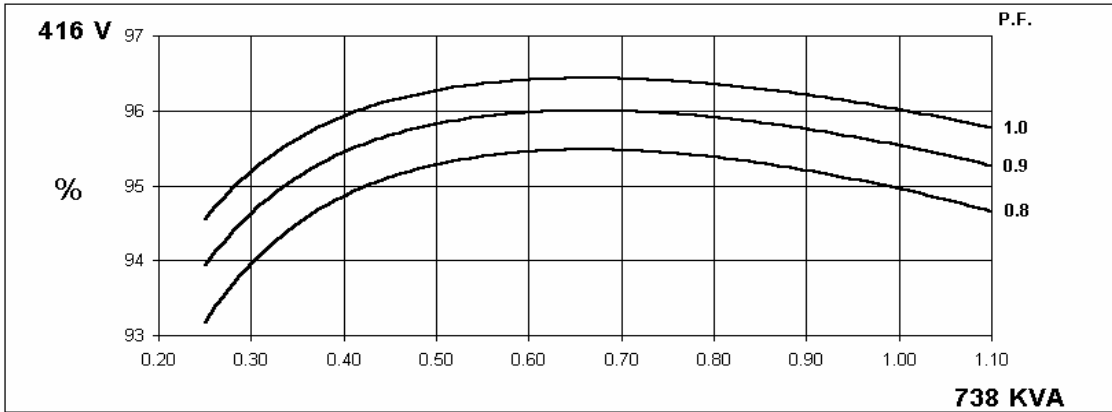

Three-phase Short Circuit Decrement Curve. No-load Excitation at Rated Speed Based on star (wye) connection.

50
Hz

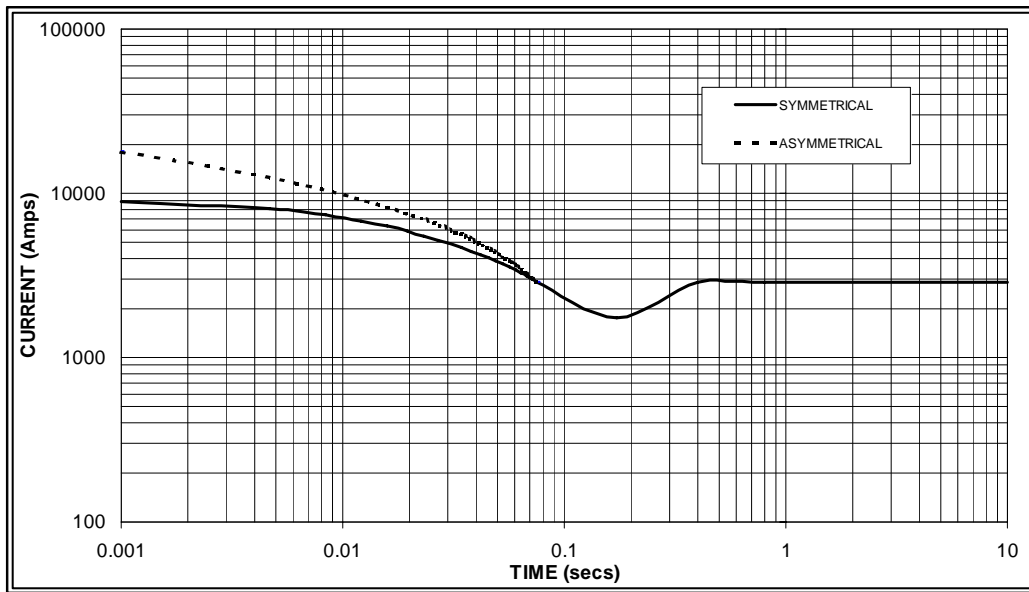

Sustained Short Circuit = 2,900 Amps

60
Hz

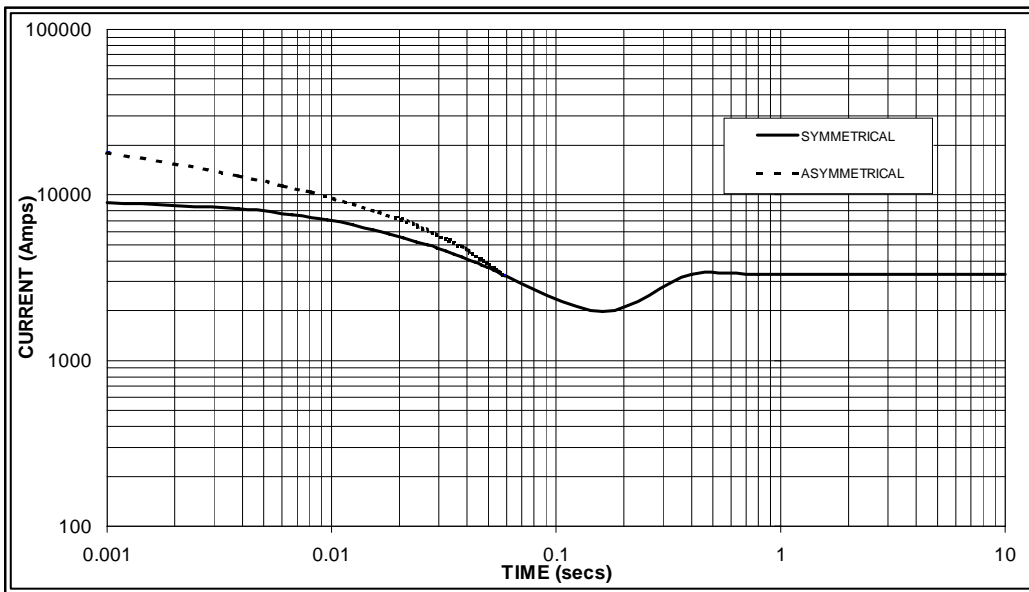

Sustained Short Circuit = 3,300 Amps

Note 1

The following multiplication factors should be used to adjust the values from curve between time 0.001 seconds and the minimum current point in respect of nominal operating voltage :

50Hz		60Hz	
Voltage	Factor	Voltage	Factor
380v	X 1.00	416v	X 1.00
400v	X 1.06	440v	X 1.06
415v	X 1.09	460v	X 1.12
440v	X 1.12	480v	X 1.20

The sustained current value is constant irrespective of voltage level

Note 2

The following multiplication factor should be used to convert the values calculated in accordance with NOTE 1 to those applicable to the various types of short circuit :

	3-phase	2-phase L-L	1-phase L-N
Instantaneous	x 1.00	x 0.87	x 1.30
Minimum	x 1.00	x 1.80	x 3.20
Sustained	x 1.00	x 1.50	x 2.50
Max. sustained duration	10 sec.	5 sec.	2 sec.

All other times are unchanged

Note 3

Curves are drawn for Star (Wye) connected machines. For other connections the following multipliers should be applied to current values as shown :

Parallel Star = Curve current value X 2

Series Delta = Curve current value X 1.732

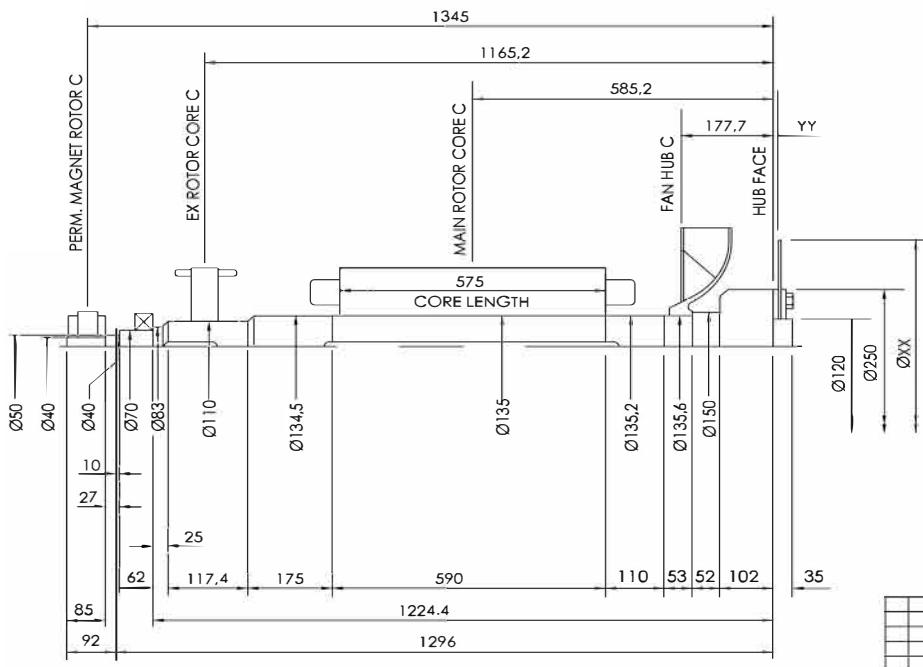

COMPONENT	Wt kg	J kgm ²
EX. ROTOR	31,290	0,5100
MAIN ROTOR	470	8.56
FAN	12.53	0,393
SHAFT	138.092	0,3062
HUB	23.922	0,2455
TOTAL	675.834	10.0147
PERM. MAG.	7.899	0,0183
TOTAL	683.733	10.033

COUPLING SAE No	COUPLING DIMEN's		COUPLING ASSEMBLY WEIGHT kg	COUPLING DISC J kgm ²
	XX	YY		
11,5	352	23,8	12,08	0,055
14	467	9,5	11,66	0,172
18	572	0,0	12,07	0,386

VER	MOD	DRW	Date		1:1
Design		APP			mm
CHK		Date	2018.01		

