

DOOSAN INFRACORE GENSETS ENGINES

SP344CC



Engine Model	rpm	Gross Engine Output[kWm]	
		Stand-by	Prime
SP344CC	1,500	81	73
	1,800	92	83

Ratings Definitions

Electric power(kWe) should be estimated by considering generator efficiency, cooling fan power loss and power derating due to altitude and ambient temperature.

STANDBY POWER RATING is applicable for supplying emergency power for the duration of the utility power outage.

No overload capability is available for this rating. A standby rated engine should be sized for a maximum of an 70% average load factor and 200 hours of operation per year. This includes less than 25 hours per year at the Standby Power rating.

PRIME POWER RATING is available for an unlimited of hours per year in variable load application. Variable load should not exceed a 70% average of the Prime Power rating during any operating period of 24 hours. The Total operating time at 100% Prime Power shall not exceed 500 hours per year. A 10% overload capability is available for a period of 1 hour within a 12 hour period of operation.

Total operating time at the 10% overload power shall not exceed 25 hours per year.

◎ GENERAL ENGINE DATA

○ Engine Model	SP344CC
○ Engine Type	4-stroke, in-line 4 cylinder, water cooled, common rail direct injection
○ Bore x stroke	98 × 113 mm
○ Displacement	3.4 liters
○ Compression ratio	16.8 : 1
○ Rotation	Clockwise viewed from the front
○ Firing order	1 - 3 - 4 - 2
○ Dry weight	472 kg (Genset condition)
○ Dimension (LxWxH)	1138.5 × 783 × 1135 mm
○ Idle speed	800 ±15 rpm
○ Governor Regulation	≤ 5 %
○ Maximum permissible high altitude (No torque derating)	2500 m
○ Moment of inertia	0.804 kgm ²
○ Flywheel Housing	SAE #3 (SAE J617)
○ Flywheel Clutch Size	11-1/2" (SAE J620)
○ No. of Ring Gear Teeth	125

◎ AIR INTAKE SYSTEM

○ The maximum temperature rise	15 °C
○ Maximum inlet temperature	52 °C
○ Minimum inlet pressure	100 kPa
○ Max. permissible air intake restriction at engine (dirty filter)	6.5 kPa
○ Max. permissible air intake restriction at engine (clean filter)	3 kPa
○ Air filter type	Dry element type
○ Minimum dirt capacity	1200 g

◎ EXHAUST SYSTEM

○ Maximum permissible back pressure for total system	6 kPa
○ Exhaust gas flow(prime)	4.5 (50HZ), 5.4 (60HZ) m ³ /min
○ Exhaust gas flow(standby)	4.7 (50HZ), 5.5 (60HZ) m ³ /min
○ Exhaust gas temperature(prime)	505 (50HZ), 530 (60HZ) °C
○ Exhaust gas temperature(standby)	550 (50HZ), 570 (60HZ) °C

◎ COOLING SYSTEM

○ Total system coolant capacity	14.2 L
○ Thermostat operation range	80 ~ 90 °C
○ Maximum permissible external system resistance	25 kPa
○ Maximum temperature to engine	105 °C
○ Minimum temperature to engine	70 °C

○ Coolant temperature alarm	105 °C
○ Limits of the environment temperature	52 °C

◎ RADIATOR SYSTEM

○ Radiator	Fin & Tube
○ Radiator cooling area	Fin: 29.9 m ² / Tube: 5.2 m ²
○ Length x height x width	740 × 977 × 338 mm
○ Pressure cap setting	0.9 ± 0.15 kPa
○ Maximum top tank temperature	105 °C

◎ FAN SYSTEM

○ Diameter	480 mm
○ Driver ratio	1 : 1.3 (Crank : Fan)
○ Number of blade	7
○ Material	Plastic

◎ LUBRICATION SYSTEM

○ Lubrication oil capacity	6 ~ 12.6 L
○ Lubrication oil pressure	min 250 kPa (50Hz) / min 300 kPa (60Hz)
○ Lubrication oil temperature	At normal operation 105 °C, Maximum 125 °C
○ Lubrication oil consumption as % of fuel consumption	0.1 % maximum
○ Pressure of oil relief valve opening	550 ± 50 kPa

◎ FUEL SYSTEM

○ Pump	High pressure common rail pump
○ System inlet pressure	0.35 ~ 1 bar (abs)
○ System pressure	1800 bar

◎ ELECTRICAL SYSTEM

○ Alternator	12 V / 110 A
○ Starter motor	12 V / 2.5 kW

◎ ENGINE DIMENSION

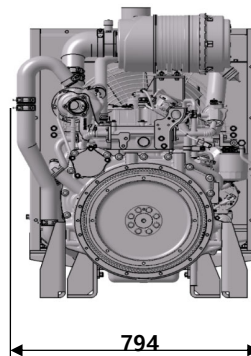
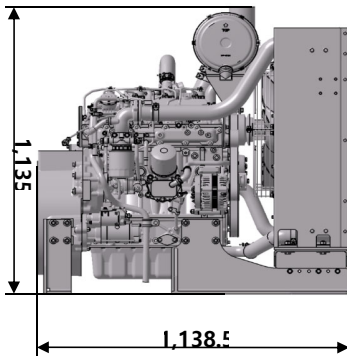

◆ CONVERSION TABLE

in. = mm x 0.0394	lb/ft = N.m x 0.737
PS = kW x 1.3596	U.S. gal = lit. x 0.264
psi = kg/cm ² x 14.2233	kW = 0.2388 kcal/s
in ³ = lit. x 61.02	lb/PS.h = g/kW.h x 0.00162
hp = PS x 0.98635	cfm = m ³ /min x 35.336
lb = kg x 2.20462	MPa = kPa x 1000 = bar x 10
kW = kcal/sec x 0.239	

Doosan Infracore Co., Ltd
 28st Floor, Doosan Tower, 18-12, Euljiro 6-ga, Jung-gu, Seoul, Korea.

TEL : +82-2-3398-8899/ FAX : +82-2-3398-8898
E-mail : enginesales@doosan.com
Web site : www.doosaninfracore.com

