

Venus Series Engines



LP612G3

LP612G3 Engine

fixed speeds
1800 r/min

307 - 338 kWm | 411.7 – 453.3 bhp²



OVER VIEW

The engine is specifically designed as a Power generating engine suitable for use in Stage II emissions territories. It is durable, reliable and easy to maintain with oil & filter changes up to 500 hours, dependant on operational conditions. It is designed for continuous operation in ambient temperatures up to 52°C (125°F) and a cold start capability down to -25°C (-13°F).

G Build

Note:

For further information and approval please contact Applications Department

* Optional items standard on most builds.

BASIC ENGINE CHARACTERISTICS

- direct fuel injection
- 6 cylinders
- liquid cooled
- Turbocharged aspirated

DESIGN FEATURES AND EQUIPMENT

- electric starting
- anti clockwise rotation, looking on the flywheelend
- SAE Flywheel connection
- SAE compliant flywheel housing
- radiator and fangard
- cast-iron structural crankcase
- self-vent fuel injection system
- mechanical fuel injection equipment
- mechanical and electronic governing variants
- flywheel and gear ring
- cyclonic heavy duty airfiltration
- oil pressure protection switch
- coolant temperature protection switch
- spin-on full flow lubricating oil filter
- fuel filter / agglomerator
- intake and exhaust manifolds
- operators' handbook

OPTIONAL ITEMS

A range of options are available that allows you to select a specification that matches your requirements; please consult your Lister Petter Power Systems distributor.

POWER OUTPUTS³ | Stage II EMISSIONS RATINGS

Model	Speed, r/min	Power	Gross ²		Net		Standard Generator Output*		
			kW	bhp	kW	bhp	Power	kVA	kWe
LP612G3	1800	Continuous	307	411.7	301	403.6	PRP	350	280
		Fuel Stop	338	453.3	332	445.2	ESP	385	308

TECHNICAL DATA

Engine fixed speed 1800r/min	LP612G3	
Type of fuel injection	Direct	
Number of cylinders	6	
Aspiration	Turbocharged and air-to-air intercooled	
Direction of rotation (flywheel end)	Anti clockwise	
Nominal cylinder bore	mm	128
	in	4.99
Stroke	mm	153
	in	5.97
Total cylinder capacity	litre	11.8
	in ³	720
Compression ratio	17:1	
Firing order (number 1 cylinder is at the gear end)	1-5-3-6-2-4	
Alternator	28V×70A	
Starter motor	24V×5.5kW	
Fuel injection pump	Mechanical	
Speed governor	Electronic	
Speed regulation class	ISO 8528 G3	
Fly wheel housing	SAE 1	
Fly wheel	SAE J620 Size 14"	

RATING DEFINITIONS TO ISO 3046

ISO Standard Conditions

Barometric pressure 100kPa
 Relative humidity 30%
 Ambient air temperature at the inlet manifold 25°C

Power Standards

The engine performance corresponds to ISO 3046, BS 5514 and DIN 6271. The technical data applies to an engine without cooling fan and operating on a fuel with calorific value of 42.7 MJ/kg (18360 BTU/lb) and a density of 0.84 kg/liter (7.01 lb/US gal, 8.42 lb/Imp gal).

Fixed Speed: Continuous Power (ICN)

The power in kW which the engine is capable of delivering continuously at the stated crankshaft speed, under ISO 3046 standard conditions, measured at the flywheel without power-absorbing accessories, provided that the engine is overhauled and maintained in good operating condition and that fuel to BS EN 590 Class A1 or A2, and lubricating oils to the correct performance specification and viscosity classification as recommended by Lister Petter Engine Company are used.

Fixed Speed (Fuel Stop): Overload Power (ICXN)

The maximum power in kW which the engine is capable of delivering intermittently at the stated crankshaft speed for a period not exceeding one hour in any period of twelve hours of continuous running, immediately after working at the continuous power, under ISO 3046 standard conditions and with the provisions specified for continuous power in item (1) above, but with the fuel limited so that the fuel stop power cannot be exceeded.

Derating

For non-standard site conditions, reference should be made to relevant BS, ISO & DIN standards.

Notes:

1. Power ratings are measured at the flywheel end.
- 2.. Power ratings and fuel consumption figures apply to a fully run-in, non derated engine without a radiator and fan fitted, and without power absorbing accessories or transmission equipment.

* The power output of the generator data is calculated using a typical efficiency of the AC generator. The kVA and kWe values are converted as per standard power factor 0.8. Generator data is for reference only.

EXHAUST AND INTAKE SYSTEM | 1800 RPM FIXED SPEED ENGINES

Parameter	Engine Model
	LP612G3
EXHAUST	
Maximum allowable back-pressure (kPa)	≤ 10
Exhaust gas flow, (m ³ /min)	82
Emissions level	Stage II
Exhaust gas temperature, continuous (°C)	550
Exhaust gas temperature, overload (°C)	600
Exhaust pipe diameter - recommended	120mm
INTAKE	
Maximum allowable inlet restriction (kPa)	≤ 6
Combustion air flow (m ³ /min)	34

ENGINE COOLANT SYSTEM | 1800 RPM, FIXED SPEED

Parameter	Engine Model
	LP612G3
Cooling method	Liquid cooled (belt driven water pump)
RADIATOR	
Material	Aluminium
Radiator face area (m ²)	95
Pressure cap setting (kPa)	70
FAN	
Diameter (mm)	843
Number of blades	8
Material	Plastic
Type	Blower type
COOLANT	
Cooling package maximum operating temperature (°C)	≤104
Total system with radiator capacity (L)	56
Total system without radiator capacity (L)	28
Thermostat type	Wax Capsule
Thermostat opens at... (°C)	82
Thermostat fully open at... (°C)	≤ 95
Minimum temperature to engine (°C)	-25
Maximum static pressure head at pump (meters at 1800rpm)	18
Cooling fan flow rate (m ³ /s)	8.8

Recommended coolant:

50% ethylene glycol with a corrosion inhibitor (BS 6580 : 1992 or ASTM D3306-89 or AS2108) and 50% de-ionised water

ENGINE LUBRICATION SYSTEM

Parameter	Engine Model
	LP612G3
Lubricating method	Pressure feed and splash
Sump capacity including filter (L)	41
Service Interval (hr)	500
Oil filter type	Spin-on full flow oil filter
Oil Specification	API CH-4
	ACEA E5
Oil consumption % SFC	≤ 0.1%
Oil consumption, 100% (l/hr)	0.06
Lubricating oil temperature (°C)	90-105
Maximum oil temperature (°C)	108
Maximum operation angle of engine (degrees)	25°

APPROXIMATE FUEL CONSUMPTION

		Engine model	
Speed, r/min	Load	LP612G3	
		g/kWh	l/h
1800	110%	209	84.7
	100%	206	75.8
	75%	205	56.6
	50%	212	39
	25%	221	20.3

*Diesel fuel density 0.835 g/cm³

* The power output of the engine is calculated according to NPT conditions.

* For non-standard site conditions not listed, reference should be made to BS, ISO and DIN standards.

* Inquiry should always be made to the technical department of the respective manufacturer if the attitude is above 3000m.

ENGINE NOISE LEVELS

Parameter	Engine Model
	LP612G3
Sound pressure level at 1m	≤95dB(A)

APPROXIMATE DIMENSIONS AND WEIGHT

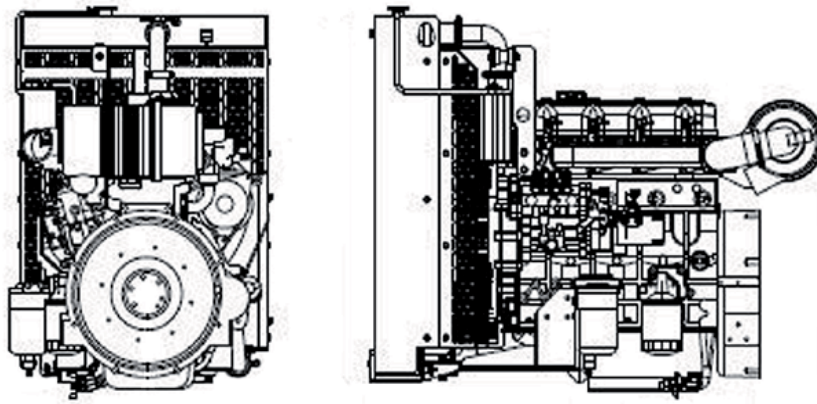

Engine model		LP612G3
Dry weight	kg	1336
	lb	2939
Length (A)	mm	2248
	in	87.7
Width (B)	mm	1155
	in	45.0
Height (C)	mm	1482
	in	57.8

TYPICAL PACKING CASE DIMENSIONS

Engine packing case dimensions	Radiator packing case dimensions	Container quantities (Engine with Radiator)		
		20FT	40FT	40HQ
L*W*H(mm)	W*D*H(mm)			
2000*1100*1600	1245*640*1658	4 sets	8 sets	8 sets



Head Office
Lister Petter Engine Company Limited

Rutland House, Minerva Business Park,
Lynch Wood, Peterborough, PE2 6PZ.

Distributor Address



enquiry@listerpetter.com
www.listerpetter.com