

Mars Max Series Engines



LP625EG2

LP625EG2 Engine

fixed speeds
1800 r/min

572 - 629 kWm | 767.1 – 843.5 bhp²

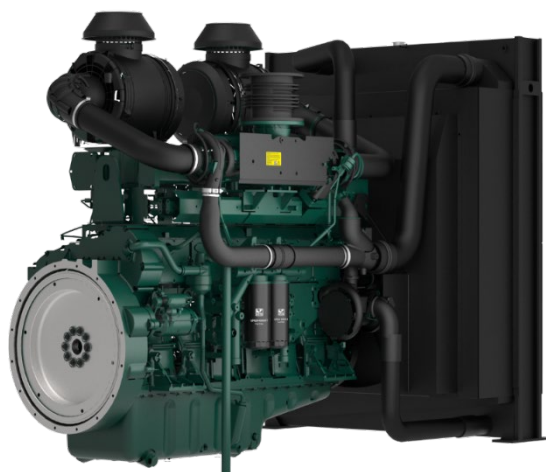

OVER VIEW

The engine is specifically designed as a Power generating engine suitable for use in Stage III emissions territories. It is durable, reliable and easy to maintain with oil & filter changes up to 500 hours, dependant on operational conditions. It is designed for continuous operation in ambient temperatures up to 52°C (125°F) and a cold start capability down to -25°C (-13°F).

G Build

Note:

For further information and approval please contact Applications Department

* Optional items standard on most builds.

BASIC ENGINE CHARACTERISTICS

- Electronic control injection
- 6 cylinders
- liquid cooled
- Turbocharged aspirated

DESIGN FEATURES AND EQUIPMENT

- electric starting
- anti clockwise rotation, looking on the flywheel end
- SAE Flywheel connection
- SAE compliant flywheel housing
- radiator and fan guard
- cast-iron structural crankcase
- self-vent fuel injection system
- HPCR fuel injection equipment
- ECU governing
- flywheel and gear ring
- cyclonic heavy duty airfiltration
- oil pressure protection switch
- coolant temperature protection switch
- spin-on full flow lubricating oil filter
- fuel filter / agglomerator
- intake and exhaust manifolds
- operators' handbook

OPTIONAL ITEMS

A range of options are available that allows you to select a specification that matches your requirements; please consult your Lister Petter Engine distributor.

POWER OUTPUTS³ | Stage III EMISSIONS RATINGS

Model	Speed, r/min	Power	Gross ²		Net		Standard Generator Output*		
			kW	bhp	kW	bhp	Power	kVA	kWe
LP625EG2	1800	Continuous	572	767.1	550	737.6	PRP	638	510
		Fuel Stop	629	843.5	607	814	ESP	700	560

TECHNICAL DATA

Engine fixed speed 1800r/min	LP625EG2	
Type of fuel injection	Direct	
Number of cylinders	6	
Aspiration	Turbocharged and air-to-air intercooled	
Direction of rotation (flywheel end)	Anti clockwise	
Nominal cylinder bore	mm	170
	in	6.63
Stroke	mm	185
	in	7.22
Total cylinder capacity	litre	25.18
	in ³	1536
Compression ratio	14.5:1	
Firing order (number 1 cylinder is at the gear end)	1-5-3-6-2-4	
Alternator	28V×55A	
Starter motor	24V×9kW	
Fuel injection pump	HPCR fuel injection	
Speed governor	ECU	
Speed regulation class	ISO 8528 G3	
Fly wheel housing	SAE 0	
Fly wheel	SAE J620 Size 18"	

RATING DEFINITIONS TO ISO 3046**ISO Standard Conditions**

Barometric pressure 100kPa
Relative humidity 30%
Ambient air temperature at the inlet manifold 25°C

Power Standards

The engine performance corresponds to ISO 3046, BS 5514 and DIN 6271. The technical data applies to an engine without cooling fan and operating on a fuel with calorific value of 42.7 MJ/kg (18360 BTU/lb) and a density of 0.84 kg/liter (7.01 lb/US gal, 8.42 lb/Imp gal).

Fixed Speed: Continuous Power (ICN)

The power in kW which the engine is capable of delivering continuously at the stated crankshaft speed, under ISO 3046 standard conditions, measured at the flywheel without power-absorbing accessories, provided that the engine is overhauled and maintained in good operating condition and that fuel to BS EN 590 Class A1 or A2, and lubricating oils to the correct performance specification and viscosity classification as recommended by Lister Petter Engine Company are used.

Fixed Speed (Fuel Stop): Overload Power (ICXN)

The maximum power in kW which the engine is capable of delivering intermittently at the stated crankshaft speed for a period not exceeding one hour in any period of twelve hours of continuous running, immediately after working at the continuous power, under ISO 3046 standard conditions and with the provisions specified for continuous power in item (1) above, but with the fuel limited so that the fuel stop power cannot be exceeded.

Derating

For non-standard site conditions, reference should be made to relevant BS, ISO & DIN standards.

Notes:

- Power ratings are measured at the flywheel end.
- Power ratings and fuel consumption figures apply to a fully run-in, non derated engine without a radiator and fan fitted, and without power absorbing accessories or transmission equipment.

* The power output of the generator data is calculated using a typical efficiency of the AC generator. The kVA and kWe values are converted as per standard power factor 0.8. Generator data is for reference only.

EXHAUST AND INTAKE SYSTEM | 1800 RPM FIXED SPEED ENGINES

Parameter	Engine Model
	LP625EG2
EXHAUST	
Maximum allowable back-pressure (kPa)	≤ 10
Exhaust gas flow, (m ³ /min)	139
Emissions level	Stage III
Exhaust gas temperature, continuous (°C)	450
Exhaust gas temperature, overload (°C)	500
Exhaust pipe diameter - recommended	152mm
INTAKE	
Maximum allowable inlet restriction (kPa)	≤ 6
Combustion air flow (m ³ /min)	52

ENGINE COOLANT SYSTEM | 1800 RPM, FIXED SPEED

Parameter	Engine Model
	LP625EG2
Cooling method	Liquid cooled (belt driven water pump)
RADIATOR	
Material	Aluminium
Radiator face area (m ²)	220
Pressure cap setting (kPa)	70
FAN	
Diameter (mm)	1220
Number of blades	8
Material	Plastic
Type	Blower type
COOLANT	
Cooling package maximum operating temperature (°C)	≤99
Total system with radiator capacity (L)	140
Total system without radiator capacity (L)	55
Thermostat type	Wax Capsule
Thermostat opens at... (°C)	77
Thermostat fully open at... (°C)	≤ 90
Minimum temperature to engine (°C)	-25
Maximum static pressure head at pump (meters at 1800rpm)	18
Cooling fan flow rate (m ³ /s)	10.8

Recommended coolant:

50% ethylene glycol with a corrosion inhibitor (BS 6580 : 1992 or ASTM D3306-89 or AS2108) and 50% de-ionised water

ENGINE LUBRICATION SYSTEM

Parameter	Engine Model
	LP625EG2
Lubricating method	Pressure feed and splash
Sump capacity including filter (L)	75
Service Interval (hr)	500
Oil filter type	Spin-on full flow oil filter
Oil Specification	API CH-4
	ACEA E5
Oil consumption % SFC	≤ 0.1%
Oil consumption, 100% (l/hr)	0.06
Lubricating oil temperature (°C)	90-105
Maximum oil temperature (°C)	108
Maximum operation angle of engine (degrees)	10°

APPROXIMATE FUEL CONSUMPTION

		Engine model	
Speed, r/min	Load	LP625EG2	
		g/kWh	l/h
1800	110%	206	155
	100%	204	140
	75%	206	106
	50%	216	74
	25%	257	44

*Diesel fuel density 0.835 g/cm³

* The power output of the engine is calculated according to NPT conditions.

* For non-standard site conditions not listed, reference should be made to BS, ISO and DIN standards.

* Inquiry should always be made to the technical department of the respective manufacturer if the attitude is above 3000m.

ENGINE NOISE LEVELS

Parameter	Engine Model
	LP625EG2
Sound pressure level at 1m	≤95dB(A)

APPROXIMATE DIMENSIONS AND WEIGHT

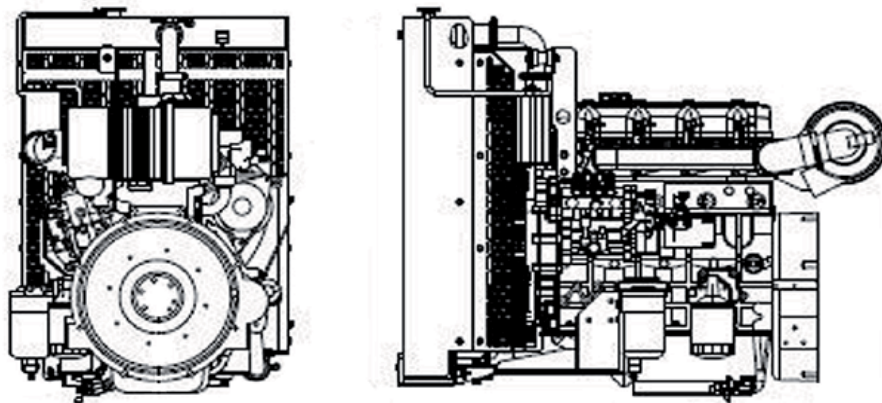

Engine model		LP625EG2
Dry weight	kg	2900
	lb	6380
Length (A)	mm	2635
	in	102.8
Width (B)	mm	1608
	in	62.7
Height (C)	mm	1936
	in	75.5

TYPICAL PACKING CASE DIMENSIONS

Engine packing case dimensions	Radiator packing case dimensions	Container quantities (Engine with Radiator)		
L*W*H(mm)	W*D*H(mm)	20FT	40FT	40HQ
2300*1600*2200	1703*770*2054	2 sets	5 sets	5 sets



Head Office
Lister Petter Engine Company Limited

Rutland House, Minerva Business Park,
Lynch Wood, Peterborough, PE2 6PZ.

Distributor Address



enquiry@listerpetter.com
www.listerpetter.com