

TAD1380-1382GE

12.78 liter, in-line 6 cylinder

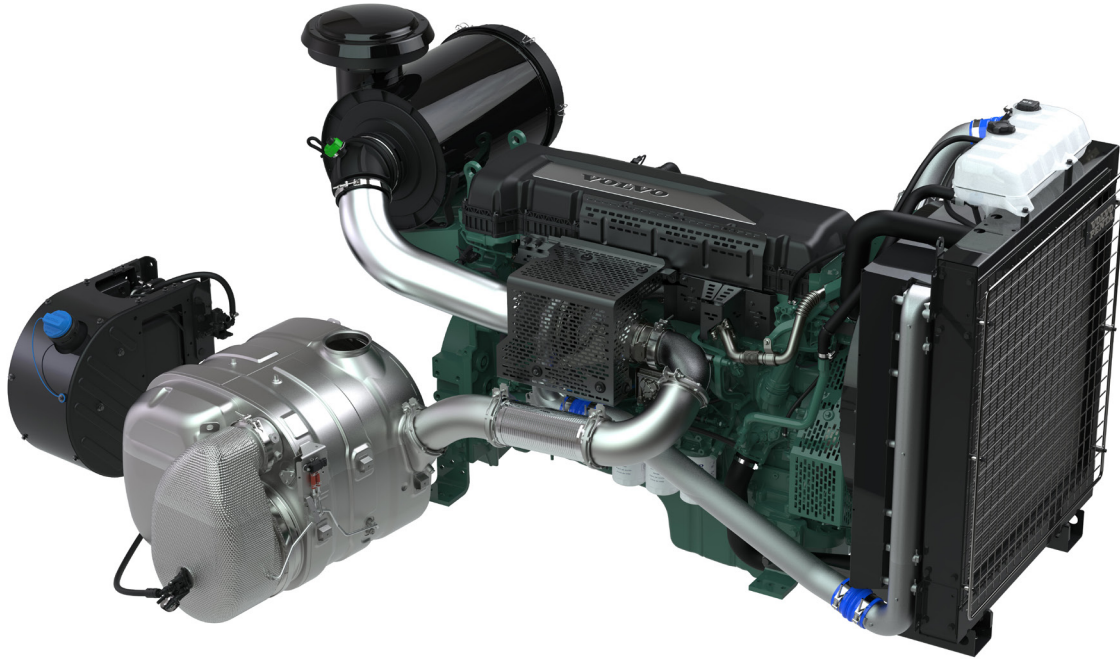

The TAD1380-1382GE is a powerful, reliable and economical Generating Set Diesel Engine built on the dependable in-line six design.

Durability & low noise

Designed for easiest, fastest and most economical installation. Well-balanced to produce smooth and vibration-free operation with low noise level.

To maintain a controlled working temperature in cylinders and combustion chambers, the engine is equipped with piston cooling. The engine is also fitted with replaceable cylinder liners and valve seats/guides to ensure maximum durability and service life of the engine.

Low exhaust emission

The state of the art, high-tech injection and charging system with low internal losses contributes to excellent combustion and low fuel consumption.

Chosen engine design combined with optimized DPF/SCR technology ensures that TAD1380-1382GE complies with EU Stage V emission regulations.

Easy service & maintenance

Easily accessible service and maintenance points contribute to the ease of service of the engine.

- Electronic governing EMS 2.4
- CAN bus communication
- High power to weight ratio
- Emission compliant acc. to EU Stage V
- Noise optimized engine design
- RoHS2 Compliant
- Dual speed
- Excellent passive soot regeneration

50 Hz / 1500 rpm

60 Hz / 1800 rpm

	Continuous power			Prime power			Standby power			Continuous power			Prime power			Standby power		
	kWm	kWe	kVA	kWm	kWe	kVA	kWm	kWe	kVA	kWm	kWe	kVA	kWm	kWe	kVA	kWm	kWe	kVA
TAD1380GE	195	181	227	260	242	302	286	266	332	205	191	239	274	254	318	301	280	350
TAD1381GE	227	211	264	303	282	352	333	310	387	237	220	276	316	294	367	347	323	403
TAD1382GE	255	240	300	340	320	400	374	352	440	255	240	300	340	320	400	374	352	440

Generator efficiency: TAD1380GE/TAD1381GE 93%, TAD1382GE 94%

kWm = kiloWatt mechanical, net with fan; kWe = kiloWatt electrical = kWm x Generator eff.; kVA = kiloVoltAmpere calculations based on a 0.8 power factor = kWe / 0.8
 1 kW = 1 hp x 1.36; 1 hp = 1 kW x 0.7355

TAD1380-1382GE

EN SAVOIR PLUS

12.78 liter, in-line 6 cylinder

Technical data

Configuration and no. of cylinders in-line 6
 Displacement, l (in³) 12.78 (780)
 Method of operation 4-stroke
 Bore, mm (in.) 131 (5.16)
 Stroke, mm (in.) 158 (6.22)
 Wet weight *, engine only, kg (lb) 1267 (2793)
 Compression ratio 16.8:1
 Direction of rotation (viewed towards flywheel) counterclockwise
 *) The engine is weighed with components that consist of the minimum running weight including standard flywheel and excluding cooling package, hoses and air filters.

Technical description

Engine and block

- Cast iron cylinder block
- Wet, replaceable cylinder liners
- Replaceable valve guides and valve seats
- Overhead camshaft and four valves per cylinder
- Flywheel housing with connection according to SAE 1

Lubrication system

- Full flow disposable spin-on filter, for extra high filtration
- Gear type lubrication oil pump, gear driven by transmission
- Oil level sensor

Fuel system

- Electronically controlled common rail injectors
- Fuel pre filter with water separator and water-in-fuel indicator/alarm
- Gear driven low-pressure fuel pump
- Fine fuel filter with manual feed pump and fuel pressure valve

Cooling system

- Belt driven coolant pump with high degree of efficiency
- Fan and fan ring available as option

Electrical system

- Engine Management System 2 (EMS 2.4), includes advanced facilities for diagnostics and fault tracing.
- The instruments and controls connect to the engine via the CAN SAE J1939 interface. Options available for engine control equipment.

Exhaust after treatment system

- SCR, DPF+ DOC and uncooled EGR
- Airless urea injection
- Wide range of options available, including different sized AUS/DEF tanks (also possible for OEM to design own tank).
- AUS/DEF Quality Level Temperature Sensor

Dimensions

Not for installation. Dimensions in mm.

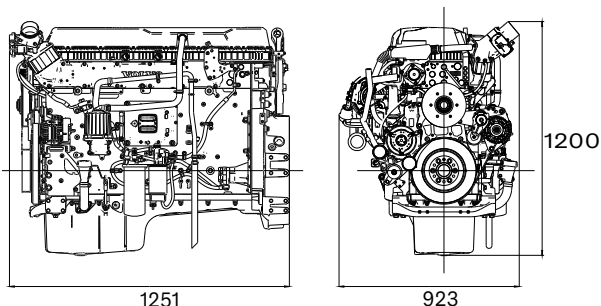

Main components

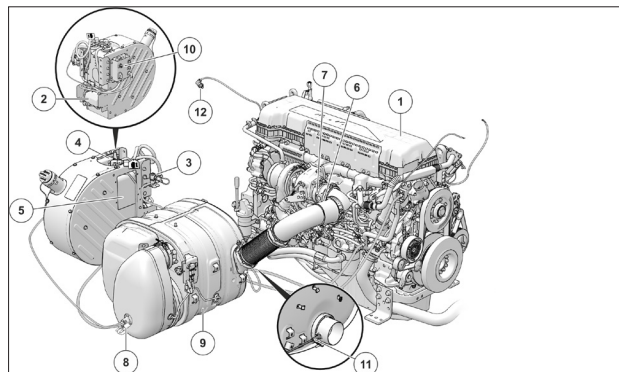

1. Engine with common rail fuel injection
2. AdBlue Pump Unit
3. Solenoid Valve, heating
4. Tank armature with sensors and heater
5. AdBlue tank, heated
6. NOx Sensor
7. Electrical Exhaust Pressure Governor
8. Dosage Valve
9. Muffler with Catalytic Converter and diesel particulate filter
10. After treatment Control Module (ACM)
11. NOx Sensor
12. Air inlet Temperature Sensor and pressure sensor

All necessary components are available in various lengths and sizes, cables, heated hoses and tanks. A complete system.

Fuel consumption

Prime Power, g/kWh (lb/hph)

	TAD1380GE		TAD1381GE		TAD1382GE	
	1500 rpm	1800 rpm	1500 rpm	1800 rpm	1500 rpm	1800 rpm
25%	236 (0.383)	263 (0.426)	222 (0.360)	256 (0.415)	217 (0.351)	252 (0.408)
50%	204 (0.331)	218 (0.353)	201 (0.326)	214 (0.347)	199 (0.322)	212 (0.344)
75%	197 (0.319)	208 (0.337)	196 (0.318)	206 (0.334)	196 (0.318)	207 (0.336)
100%	196 (0.318)	207 (0.336)	197 (0.319)	206 (0.334)	198 (0.320)	205 (0.333)

Standby Power, g/kWh (lb/hph)

	TAD1380GE		TAD1381GE		TAD1382GE	
	1500 rpm	1800 rpm	1500 rpm	1800 rpm	1500 rpm	1800 rpm
25%	226 (0.366)	259 (0.420)	218 (0.353)	250 (0.405)	213 (0.346)	234 (0.379)
50%	203 (0.329)	216 (0.350)	199 (0.323)	213 (0.345)	197 (0.320)	211 (0.341)
75%	197 (0.319)	207 (0.336)	196 (0.318)	208 (0.337)	196 (0.318)	207 (0.336)
100%	197 (0.319)	207 (0.336)	197 (0.319)	206 (0.334)	200 (0.324)	207 (0.336)

Rating guidelines

CONTINUOUS POWER is defined as being the maximum power which the generating set is capable of delivering continuously while supplying a constant electrical load when operated for an unlimited number of hours per year under the agreed operating conditions with the maintenance intervals and procedures being carried out as prescribed by the manufacturer.

PRIME POWER rating corresponds to ISO Standard Power for continuous operation. It is applicable for supplying electrical power at variable load for an unlimited number of hours instead of commercially purchased power. A10 % overload capability for governing purpose is available for this rating.

STAND-BY POWER rating corresponds to ISO Standard Fuel Stop Power. It is applicable for supplying stand-by electrical power at variable load in areas with well established electrical networks in the event of normal utility power failure. No overload capability is available for this rating.

Power standards

The engine performance corresponds to ISO 3046, BS 5514 and DIN 6271. The technical data applies to an engine without cooling fan and operating on a fuel with calorific value of 42.7 MJ/kg (18360 BTU/lb) and a density of 0.84 kg/liter (7.01 lb/US gal), also where this involves a deviation from the standards. Ratings are based on ISO 8528. Engine speed governing in accordance with ISO 8528-5 G3.

Please contact your local Volvo Penta dealer for further information. Please note that products illustrated may differ from production models. Not all models and accessories are available in all markets, and standard equipment may vary between different markets. Every effort has been made to ensure that facts and figures are correct at the time of publication. However, Volvo Penta reserves the right to make changes without prior notice at any time.

**VOLVO
PENTA**

AB Volvo Penta

SE-405 08 Göteborg, Sweden
www.volvopenta.com