



YANMAR CO.,LTD.

G3-23946-0030

4TNV106-GGE

for **50kVA** Generator

SPECIFICATIONS & DRAWINGS FOR MASS PRODUCTION

27.Jun.2007

YANMAR CO.,LTD.

Contents

G3-23946-0030

Drawing No.	Part No.	Name	Qty.	Remarks
B3-23946-0030		Out line		
E3-23907-0010		Wiring Diagram		
Z3-23915-1100		Detail of Flywheel		
G3-23946-0030		SCOPE OF SUPPLY		
		LOOSE PARTS		
	128300-13230	GASKET, SILENCER	1	
	119225-52102	PUMP, FUEL FEED	1	
	129242-55700	SEPARATOR ASSY	1	
	119643-66900	DIODE	1	for solenoid
	119650-77910	RELAY ASSY, GLOV	1	for solenoid
	128300-77920	TIMER, GLOW PLUG	1	
	129211-77920	TIMER, SECTION 1	1	for solenoid

Note :

①Since the durability of electric parts basically apply to R2 level of JIS D0203, please inform the customer not to clean with steam or high pressure water.

②Electric parts should not mounted on the engine directly (relay, timer etc.) must be kept free from wet & high humidity and be kept with good air ventilation.

Regarding the vibration of the electrical components, these vibration level must be kept less than 4G.

③Since there is the possibility of corrosion problem on engine cylinder liner or other parts, please do not sell and use the engine with EGR valve in other than emission regulated area.(Emission regulated area means North America, Europe and Japan)

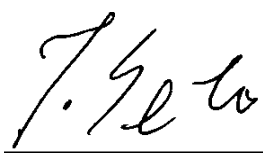
Engine Development Dept.
Manager

Sec. Manager

	For Conference	For Apporval	For Installation	Final Drawing
Customer				
Branch				
Exp. Dept.				
Copy				
Total				

Checked  Drawn Sakamoto

ENGINE SPECIFICATIONS

G3-23946-0030

No	Model name	4TNV106-GGE		Remarks	
1	Type	4 cycle, Inline, Water-cooled Diesel			
2	No. of cylinders-Bore×stroke	mm	4-φ106×125		
3	Combustion system	Direct Injection			
4	Compression ratio	18			
5	Displacement	litter	4.412		
6	Rated output	kW(PS)	49.4(67.2)/58.7(79.8)		
		min ⁻¹	1500/1800		
7	Continuous rating	kW(PS)	44.9(61)/53.3(72.5)		
		min ⁻¹	1500/1800		
8	Max. torque	N·m	~		
		min ⁻¹	(+/-)		
9	Specific fuel consumption	g/kW-h(g/PS-h)	237.6(175)	at rated output	
10	Ambient condition	25°C、750mmHg、30%			
11	Engine speed at no load	Max.	min ⁻¹	1925	+25/-25
		Min.	min ⁻¹	1500	+25/-25
12	Governorability	Governor type	centrifugal-all speed governor		
		Temporary	%	max.10	load 100% ↓ 0%
		Permanent	%	max.5	
		Recovery time	sec	max.5	
		Stability	min ⁻¹	max.15	
13	Gradients	Longitudinal	deg	15(10)	intermitted
		Lateral	deg	15(10)	(): continuous
14	Firing order	1-3-4-2-1		order from F.W.	
15	Direction of rotation	counterclockwise		viewed from F.W.	
16	Engine dry weight	kg	approx.330		
17	Fuel injection timing	deg	FIT12.0(+0.5/-0.5)	FIT b.T.D.C	
18	Fuel system	Fuel type	Diesel oil		
		Fuel injection pump	Distributor type(YPD-MP4), Yanmar made		
		Fuel injection nozzle	hole type		
		Fuel filter	paper element		
19	Lubrication system	System	forced feed		
		Oil grade	API class CD, SAE grade 10W30		
		Oil pump	trochoid pump		
		Oil filter	paper element		
		Oil capacity	liter	14	max.
			liter	9	effective.
		Oil pressure	kgf/cm ²	4.5	at rated output
kgf/cm ²	0.6		at low idle		
20	Cooling system	Heat exchanger	none		
		Pressure cap	kgf/cm ²	0.9	
		Fan	7-φ550		
		Coolant capacity	liter	6	

4TNV106-GGE

ENGINE SPECIFICATIONS

G3-23946-0030

No	Model name	4TNV106-GGE	Remarks
21	Air cleaner	none	
22	Breather system	closed	
23	Muffler	none	
24	Starting system	Starter	12V-3.0kW
		Battery	130E41
		Starting aid	air heater 1000W
25	Generator	12V-60A	
26	Engine color	Silver	
27	Applied regulation		

< Career >

	W.No.	4TNV106-GGE
--	-------	-------------

SCOPE OF SUPPLY

G3-23946-0030

No	ENGEN MODEL	4TNV106-GGE	Parts number	Remarks
FUEL SYSTEM				
1	Fuel Injection Pump	installed	723946-51310	
2	Fuel Injection Nozzle	installed	723946-53100	Mark "VCH"
3	Fuel Transfer Pump	provided	119225-52102	Electric, As loose parts
4	Fuel Filter	installed	129907-55801	1 μ , 4000cm ²
5	Fuel Filter Bracket	installed	129004-55612	
6	Fuel Injection Line	installed	123907-59800	
7	Fuel Line(Filter to Pump)	installed	119160-59010	L=400mm
8	Fuel Pipe (Pump to Filter)	installed	129957-59040	L=500mm
9	Water Separator	provided	129242-55700	Clear cup, As loose parts
10	Throttle Lever	installed	129937-61440	
LUB,OIL SYSTEM				
11	Oil Pan	installed	123900-01710	Drain: Inlet side
12	Oil filler Extension pipe	installed	124160-01751	2 places
13	Breather Pipe	not provided	none	
14	Switch ,lub .oil pressure	installed	114250-39450	0.5kg/cm2 (CA104)
15	Dipstick	installed	123982-34801	
16	Guide ,dipstick	installed	121520-34810	
17	Oil filter	installed	119005-35160	
18	Oil Cooler	not provided	123912-33011	
COOLING SYSTEM				
19	Radiator	not provided	none	
20	Rubber Isolaters	not provided	none	
21	Pipe A,radiator	not provided	none	
22	Pipe B,radiator	not provided	none	
23	Sub tank(radiator)	not provided	none	
24	Water Pump	installed	123907-42000	Low position type
25	Cooling Fan	installed	123915-44741	Mark "V6"
26	Spacer ,fan	installed	123900-44761	T=25mm
27	Guide ,fan	not provided	none	
28	Pully ,fan	installed	123900-42450	D=150mm
29	V-Belt	installed	25163-004801	Btype 48 inch
30	Switch, water temp.	installed	121250-44901	110 °C
31	Sender, water temp.	not provided	none	
32	Thermostat	installed	124610-48610	71deg
33	Thermostat Cover	installed	123962-49500	
34	Water Drain Fitting	installed	119620-49290	COCK
35	3-Way Plug ,cooling water	not provided	none	
ELECTRIC SYSTEM				
36	Starter	installed	129940-77010	12V-3.0kW (HITACHI)
37	Alternator	installed	123900-77210	12V-60A (HITACHI)
38	Relay ,solenoid	provided	119650-77910	As loose parts
39	Timer ,solenoid	provided	129211-77920	As loose parts
40	Engine Shut Off	installed	119653-77950	built-in type, Yazaki-coupler
41	Starting Aid	installed	123900-77500	12V 1kW
42	Diode ,solenoid relay	provided	119643-66900	As loose parts
43	Timer, air heater (glow)	provided	128300-77920	As loose parts
44	Relay, air heater (glow)	not provided	none	

45	Current Limiter	not provided	none	
46	Safety relay, starter	not provided	none	
PTO SYSTEM				
47	Flywheel Housing or Back plate	installed	123910-01620	SAE #3 (171.5)
48	Flywheel	installed	123915-21590	SAE #3
49	Bearing ,retainer	not provided	none	
50	Pully ,crankshaft	installed	123946-21660	D=150 mm
51	Gear case	installed	123907-01540	
52	Hydraulic Pump	not provided	none	
53	Device ,hydraulic pump	not provided	none	
INTAKE/EXHAUST SYSTEM				
54	Air Cleaner	not provided	none	
55	Bracket ,air cleaner	not provided	none	
56	Manifold ,intake	installed	123907-12100	Upward
57	Joint	installed	124610-12580	Upward
58	Muffler	not provided	none	
59	Gasket ,muffler	provided	128300-13230	As loose parts
60	Manifold ,exhaust	installed	123907-13120	Lateral
61	Bend ,exhaust	not provided	none	
62	EGR Pipe	not provided	none	
63	EGR Valve	not provided	none	
64	EGR Cooler	not provided	none	
65	Turbine	not provided	none	
ELECTRIC CONTROLL SYSTEM				
66	ECU	not provided	none	
67	Main Relay	not provided	none	
68	Lack Actuator Relay	not provided	none	
69	Starter Relay	not provided	none	
GAUGE				
70	Drive Unit ,tachometer	not provided	none	
71	Cable ,tachometer	not provided	none	
72	Tachometer	not provided	none	
73	Key Switch	not provided	none	
74	Cover ,terminals	not provided	none	
75	Pilot lamp	not provided	none	
76	Guage ,oil/water temp	not provided	none	
77	Guage ,oil pressure	not provided	none	
OTHERS				
78	Filter Wrench ,lub .oil	not provided	none	
79	Filter Wrench ,fuel .oil	not provided	none	

GEN. TOL. NEED ○

GEN. TOL.	TREAT. ING.	PURCHASING SPECIFICATION	REQUEST FOR APPROVAL	DELIVERY DRAWING		INSPECTING STANDARD				QC-PROCESS							
				NOMINAL DIM. DIVISION	SANDMOLD SHELL	5 TO ±1.0	10 TO ±1.8	18 TO ±3.0	30 TO ±5.0	L-CAST (鋳造)	120 TO ±1.5	250 TO ±3.0	400 TO ±4.0	800 TO ±6.0	1600 TO ±10.0		
		OUTSIDE 2/100	INSIDE 3/100										0.5 TO ±0.1	6 TO ±0.2	400 TO ±10.0	1000 TO ±12.0	10 MAX ±10MIN
				CAD MFG. THICKNESS									6 TO ±0.2	30 TO ±0.3	1000 TO ±12.0	2000 TO ±15.0	10 TO ±20MIN
													6 TO ±0.2	120 TO ±0.5	2000 TO ±15.0	4000 TO ±20.0	50 TO ±20MIN
													6 TO ±0.2	120 TO ±0.5	4000 TO ±20.0	8000 TO ±25.0	120 TO ±10MIN
													6 TO ±0.2	400 TO ±0.5	ANG. CHIP (削り)	400 MIN ±5MIN	

FIGURE DIMENSION GT.CODE

○ AND √: RADIAL

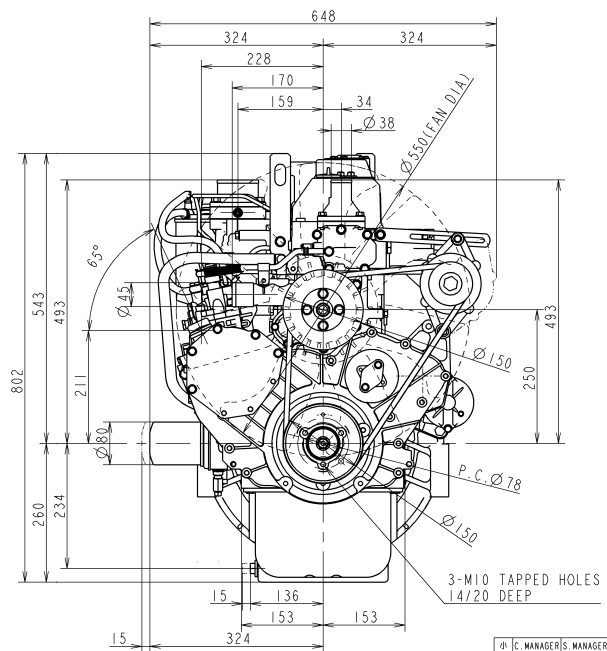
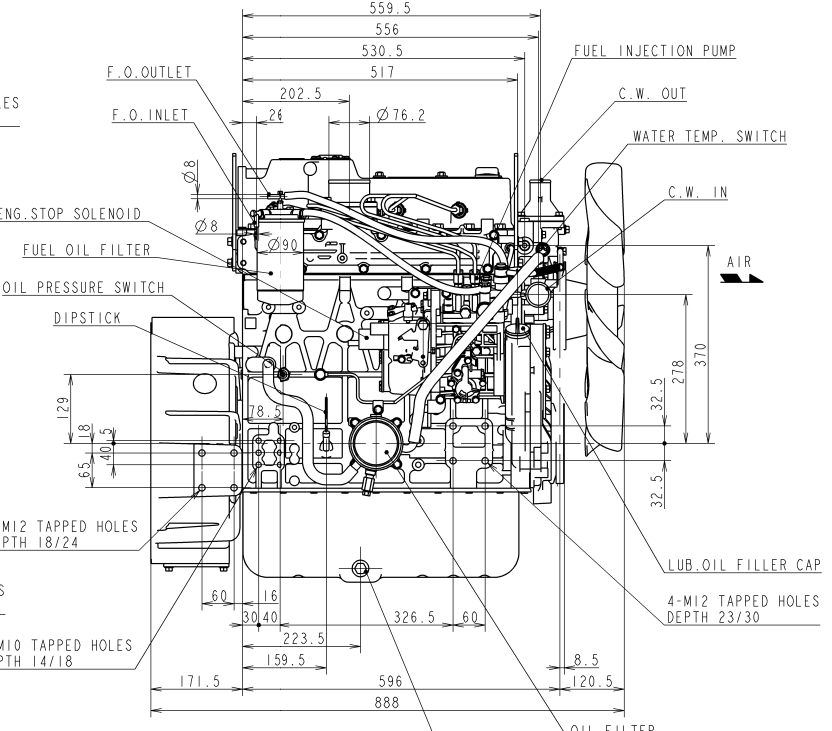
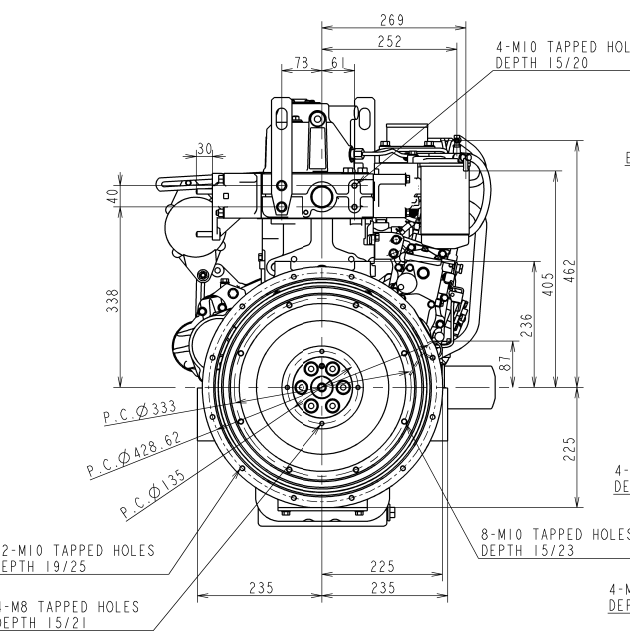
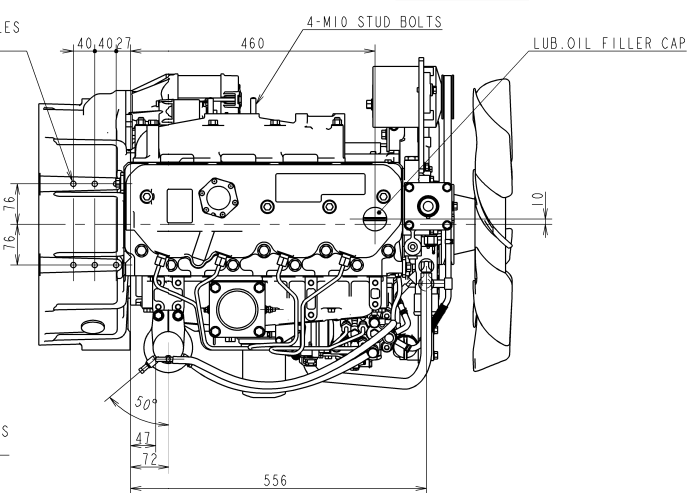
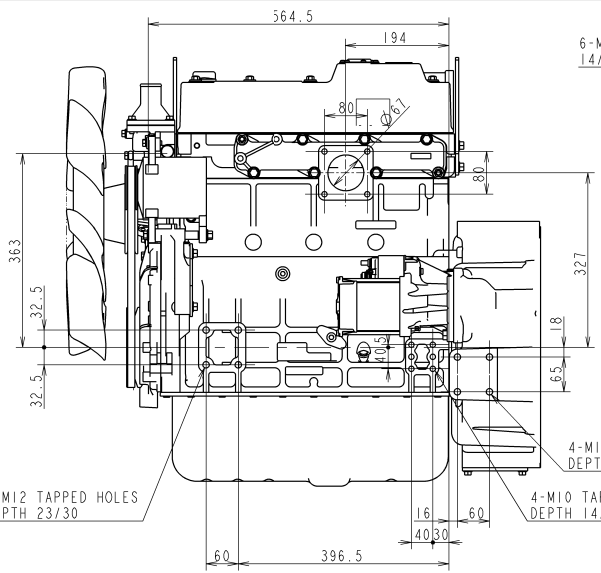

本図に示す機器は、環境性能の向上を図るため、鉛フリー溶剤を使用しております。鉛フリー溶剤は、鉛を含む溶剤に比べて、人体への健康被害を軽減する効果があります。また、鉛フリー溶剤は、燃焼時に鉛汚染物質を排出しないため、環境汚染を軽減する効果があります。

3D-CAD

NOTICE

1. DIMENSIONS

2. TOLERANCES

3. SURFACE FINISH

4. MATERIAL

5. WEIGHT

6. CENTER OF GRAVITY

7. BALANCE

8. PAINT

9. OILING POINT

10. STORAGE

WEIGHT (DRAW)	(± X)	kg	C. MANAGER'S MANAGER	
WEIGHT (CALC.)	(± X)	kg		
S. ENGINEER	MANAGER	MODEL 4TNV106-GGE	SCALE	1:5
CHECKED	SPECIALIST	QTY 1	MATERIAL	
DESIGNED	DRAWN	DATE: Y.M.D	4TNV106-GGE OUTLINE	
POWER SYSTEM OPERATIONS DIV., YANMAR CO., LTD.			CODE	B3-23946-0030

MARK	COLOR
B	Black
W	White
R	Red
L	Blue
G	Green
Y	Yellow
Br	Brown
Lg	Light Green
Sb	Sky blue
O	Orange
P	Pink
Gr	Gray
R/W	Red/White

形状寸法コード G.T.CODE 真円度・円筒度八、半径法

面来歴 CAREER

- Rev. 1 (30 May. 2002) CHANGE THE NOTES FOR ENGINE STOP SOLENOID ADD ELECTRICAL FEED PUMP (TE-02136)
- Rev. 2 (20 Sep. 2002) ADD DIODE FOR RELAY
- Rev. 3 (24 Dec. 2002) CHANGE SOLENOID ADD RELAY AND TIMER
- Rev. 4 (14 Jan. 2003) Delete Relay (119646-77900)
- Rev. 5 (5 Jun. 2003) CHANGE FUSE 20A→30A

	B	R1	R2	ACC	C	BR
PRE-HEATING	○	○	○	○	○	○
OFF	○					
ON	○					
START	○	○	○	○	○	○

KEY SW. DIAGRAM

NOTES

- WIRING OF STARTER MUST BE OBSERVED AS FOLLOWS. OTHERWISE IT CAUSES MISS STARTING OR DAMAGE OF STARTERMOTOR.
 - TOTAL ELECTRIC RESISTANCE OF BATTERY CABLE (①+②) SHOULD BE LESS THAN 2/1000Ω. REFERENCE: AV15: ≤1.4m, AV20: ≤2.2m, AV30: ≤3.8m, AV40: ≤4.6m
 - TOTAL ELECTRIC RESISTANCE OF WIRING FOR STARTER (③~⑥) SHOULD BE LESS THAN 5/100Ω. REFERENCE OF TERMINAL RESISTANCE: 15/1000Ω PER COUPLER, 0Ω PER SCREW SETTING
- BATTERY EARTH CABLE (①) CONNECTION SHALL BE ENSURED. PAINTED SURFACE MAY NOT BE USED (FOR EARTHING) AVOIDING THE MISS CONTACT.
 - BATTERY SHOULD BE FIXED BY FITTING. (NOT TO MOVE)
 - BATTERY CABLE LENGTH SHOULD BE ADJUSTED PROPERLY AND CLAMPED NOT TO BE CONNECTED REVERSELY.
 - NOT LOOSE THE BATTERY CABLE TERMINAL, NOR TURN THE BATTERY SWITCH OFF DURING THE ENGINE RUNNING.
- ONLY THE SPECIFIED LOAD SHOULD BE APPLIED ON THE ALTERNATOR "L" AND "P" LINE. IT IS NOT ALLOWED TO CONNECT ANY LOAD UNSPECIFIED WITHOUT YANMAR APPROVAL.
- CHECK ANY SURGE CURRENT OR VOLTAGE OCCURED UNDER NORMAL OPERATIONS AND EXPECTIVE ERRONEOUS OPERATIONS, AND CONFIRM THE CIRCUIT NO SURGE OCCURS. ESPECIALLY PROVIDE THE FLYWHEEL DIODE FOR "C-LOAD" AND DIODE FOR "L-LOAD".

REMARKS

- * MARKED PARTS ARE NOT PROVIDED BY YANMAR.

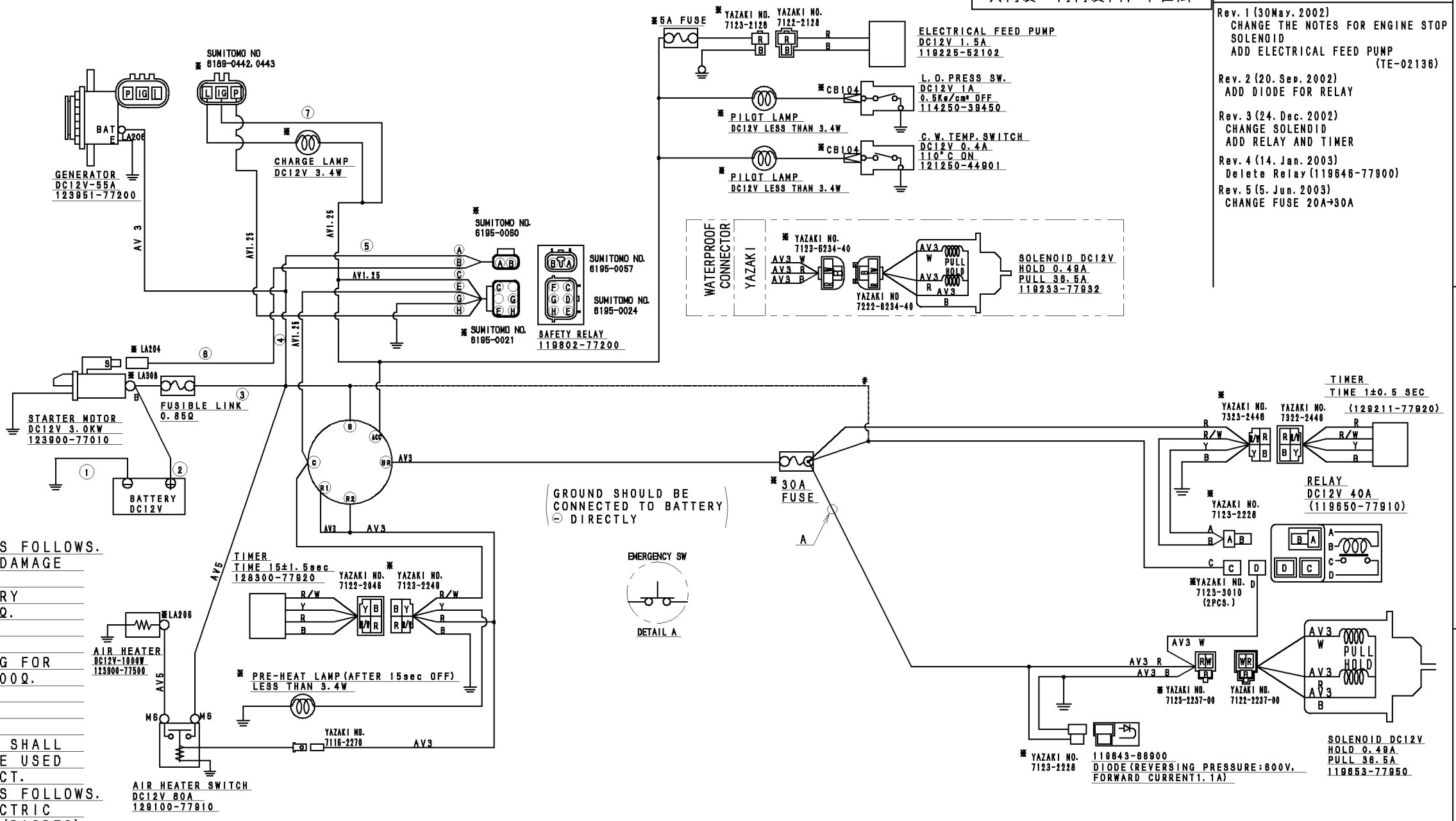

NOTES FOR ENGINE STOP SOLENOID

- PERMISSIBLE RESISTANCE OF SOLENOID CIRCUIT SHOULD BE LESS THAN 0.07Ω TO GUARANTEE PERMISSIBLE LOWEST VOLTAGE 9V TO WORK SOLENOID (PULL COIL). (TERMINAL RESISTANCE: 15/1000Ω PER COUPLER, 0Ω PER SCREW SETTING. COUPLER RESISTANCE OF SOLENOID DOESN'T NEED TO BE COUNTED) REFERENCE: AV2 (0.0088Ω/m) : ≤8.0m...WITHOUT TERMINAL RESISTANCE, AV3 (0.0056Ω/m) : ≤12.5m...SAME AS ABOVE. WHEN YOU EXCEED PERMISSIBLE RESISTANCE, ADOPT THE CIRCUIT IMPRESSED FROM THE POWER SUPPLY TO THE SOLENOID DIRECTLY USING A RELAY...REFER TO #
- HIGH TEMPERATURE PARTS, SUCH AS AN EXHAUST PIPE, SHOULD NOT APPROACH FOR THE PULL POWER FALL OF SOLENOID, AND HEATING PREVENTION OF INNER COIL TEMPERATURE. (PERMISSIBLE AMBIENT TEMPERATURE: -30~100℃)
- INSTALL FUSE TO PROTECT THE HARNESS AGAINST TROUBLES SUCH AS SHORT CIRCUIT OR CONTINUOUS DRIVE OF PULL-COIL.
- THE POWER SUPPLY OF SOLENOID MAY NOT BE COMMON WITH THE LINE OF ALTERNATOR INITIAL EXCITATOR AS SHOWN IN THIS DRAWING. (OTHERWISE, SOLENOID MAY LOOSE STOP FUNCTION DUE TO THE POWER SUPPLY FROM ALTERNATOR "L" TERMINAL.)
- IN CASE OF WATERPROOF CONNECT OR APPLICATION, CONNECTOR SHOULD BE FIXED BY FITTING TO PREVENT LEAD WIRE BREAK.
- IN CASE OF EMERGENCY STOP OF MACHINE FOR SAFETY WILL BE APPLIED, SWITCH LOCATION SHOULD BE SHOWN AS A.
- IN CASE OF THE SOLENOID CIRCUIT RESISTANCE WOULD BE LIMIT, # WIRING IS APPLICABLE.

素材質量 WEIGHT (RAW)	(± %)	水圧試験 HYDRAULIC TEST	MPa	小形工 小形工 開発部	部長 G. MANAGER	技部長 MANAGER
完成質量 WEIGHT (組立後)	(± %)	空圧試験 PNEUMATIC TEST	MPa			J. Mshida
主席	長 SEC. MANAGER Y. Yamada	機種 MODEL	4TNV 4TNV 106 106T	尺 SCALE	SCALE	SCALE OUT
検 CHECKED H. Yokoi	機能担当 SPECIALIST	個 QTY.		材 MATERIAL		
設計 DESIGNED H. Yokoi & Shimizu	製 DRAWN DATE	年月日 DATE	2002 1.29	名称 NAME WIRING DIAGRAM WIRING DIGLAM		
YANMAR CO., LTD.			Rev. 1 Rev. 2 Rev. 3 Rev. 4 Rev. 5			
ENGINE PRODUCT OPERATIONS DIV.			コード CODE E3-23907-0010			

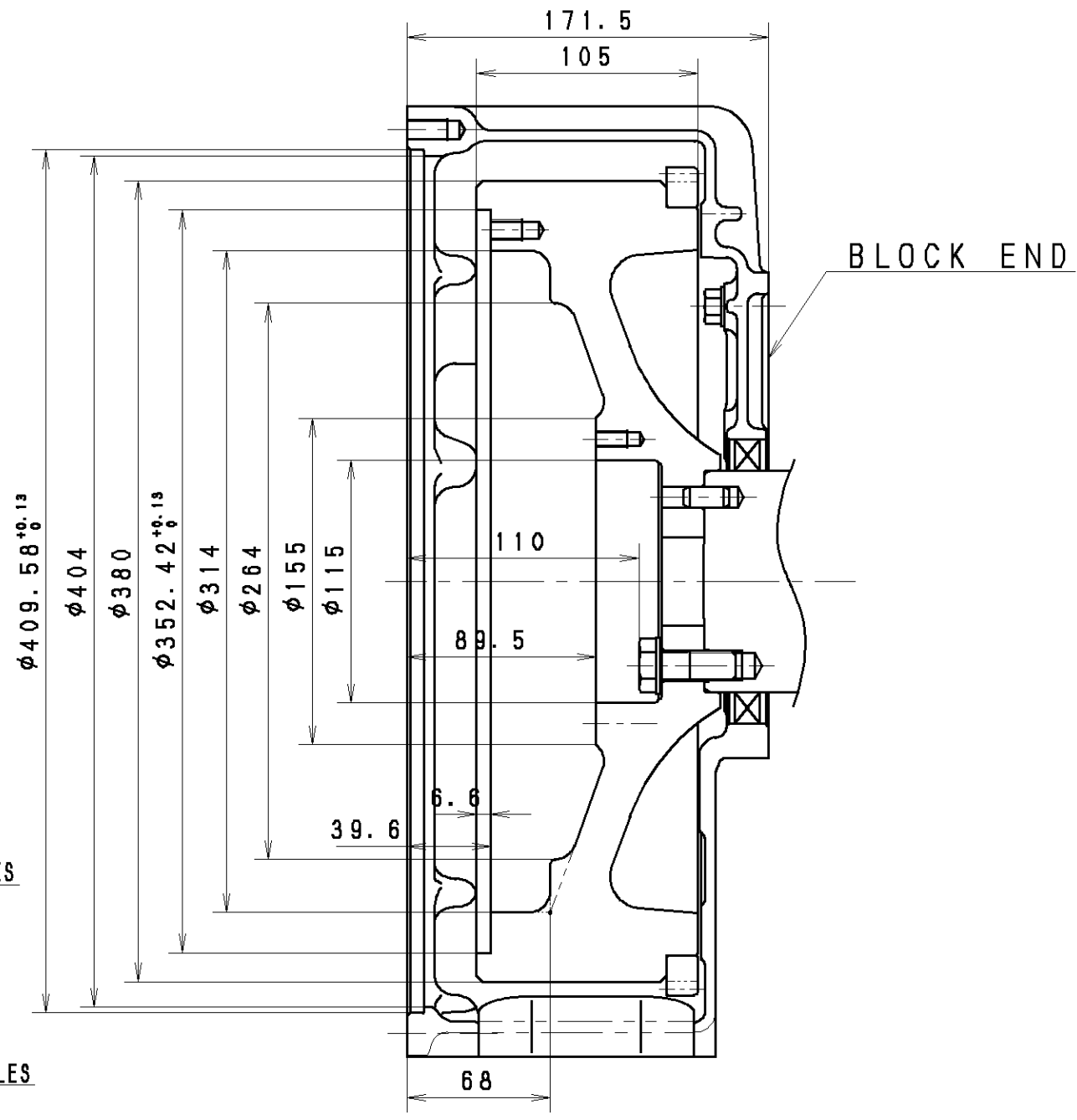
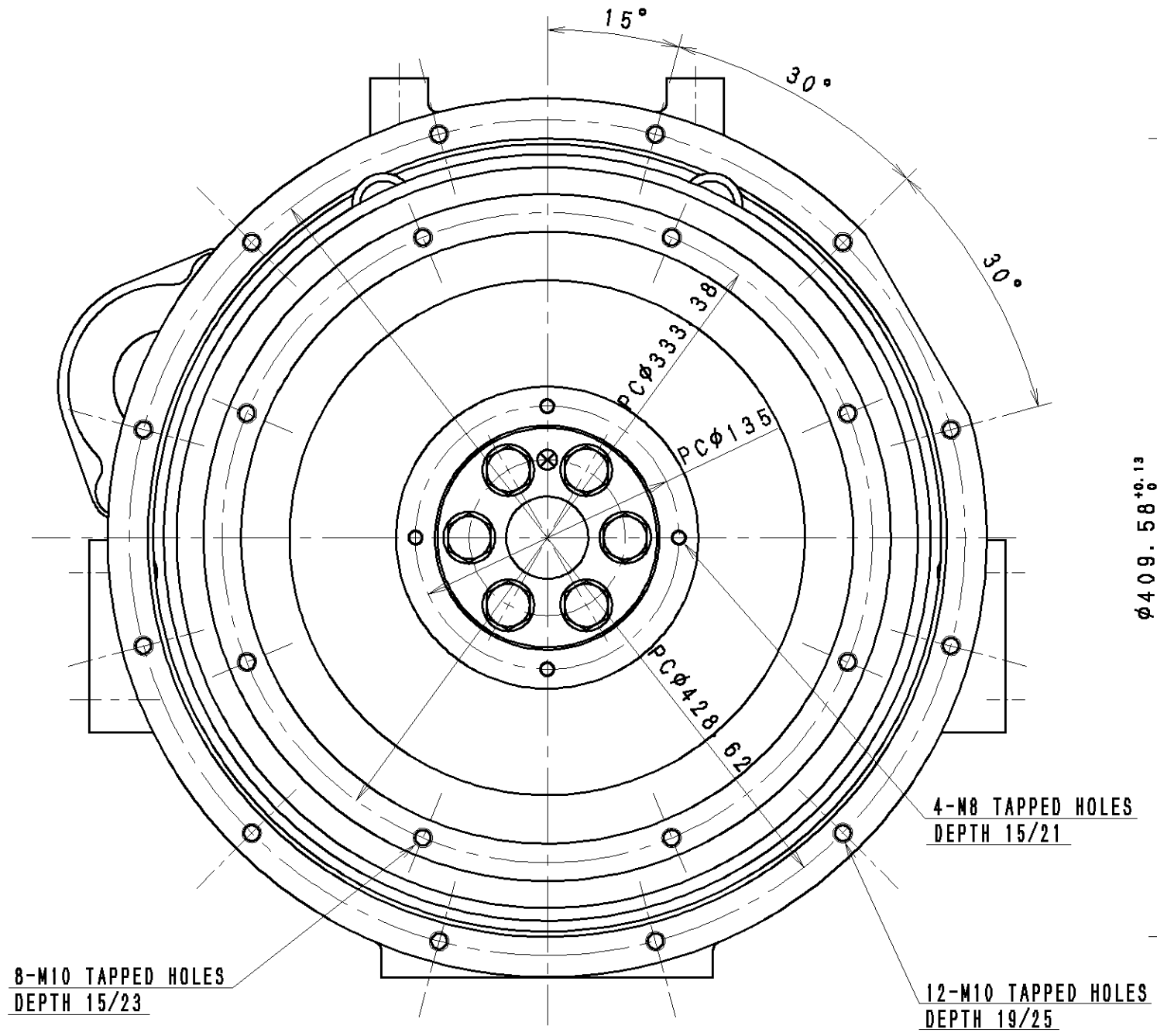

重要ポイント	○
精度/種類/記号	
種類	記号
真直度	—
真円度	○
線形	∩
平面度	□
円筒度	∩
面形	∩
平行度	//
直角度	⊥
傾斜度	∠
位置度	⊕
同軸度	◎
対称度	≡
円筒度	∩
全線公差	∩

Flywheel Housing	123910-01600
Flywheel	123915-21400
Ring Gear	127410-21480

素材質量	WEIGHT (RAW) (± %)
完成質量	WEIGHT (完成) (± %)
設計	DESIGNED
検閲	CHECKED
年月日	DATE
1999	3. 5

SEC. MANAGER	S. Yamashita
検閲	機能担当者
設計	検閲
年月日	DATE
1999	3. 5

水圧試験	MPa	検査	部長	一技長
HYDRAULIC TEST	(kg/cm ²)		MANAGER	MANAGER
空圧試験	MPa			
PNEUMATIC TEST	(kg/cm ²)			
機種	4TNE	4TNE	R 度	1/3
MODEL	106	106T	SCALE	
数量	1	1	材質	---
名称	直結部詳細図			
NAME	COUPLING DIMENSIONS			
年月日	YANMAR DIESEL ENGINE CO., LTD.		コード	A3
1999	ENGINE DEVELOPMENT DEPT.		CODE	(B)
3. 5	GROUP. USER=?			

Fig. 4TNV106 Engine performance curve

n-BxS:4-106x125
 Displacement : 4.412zl

Silencer	123900-13502
Air cleaner	8inch
CW fan	123915-44741

Crank pulley	D=150
Fan puley	D=150
φ 550	PushF

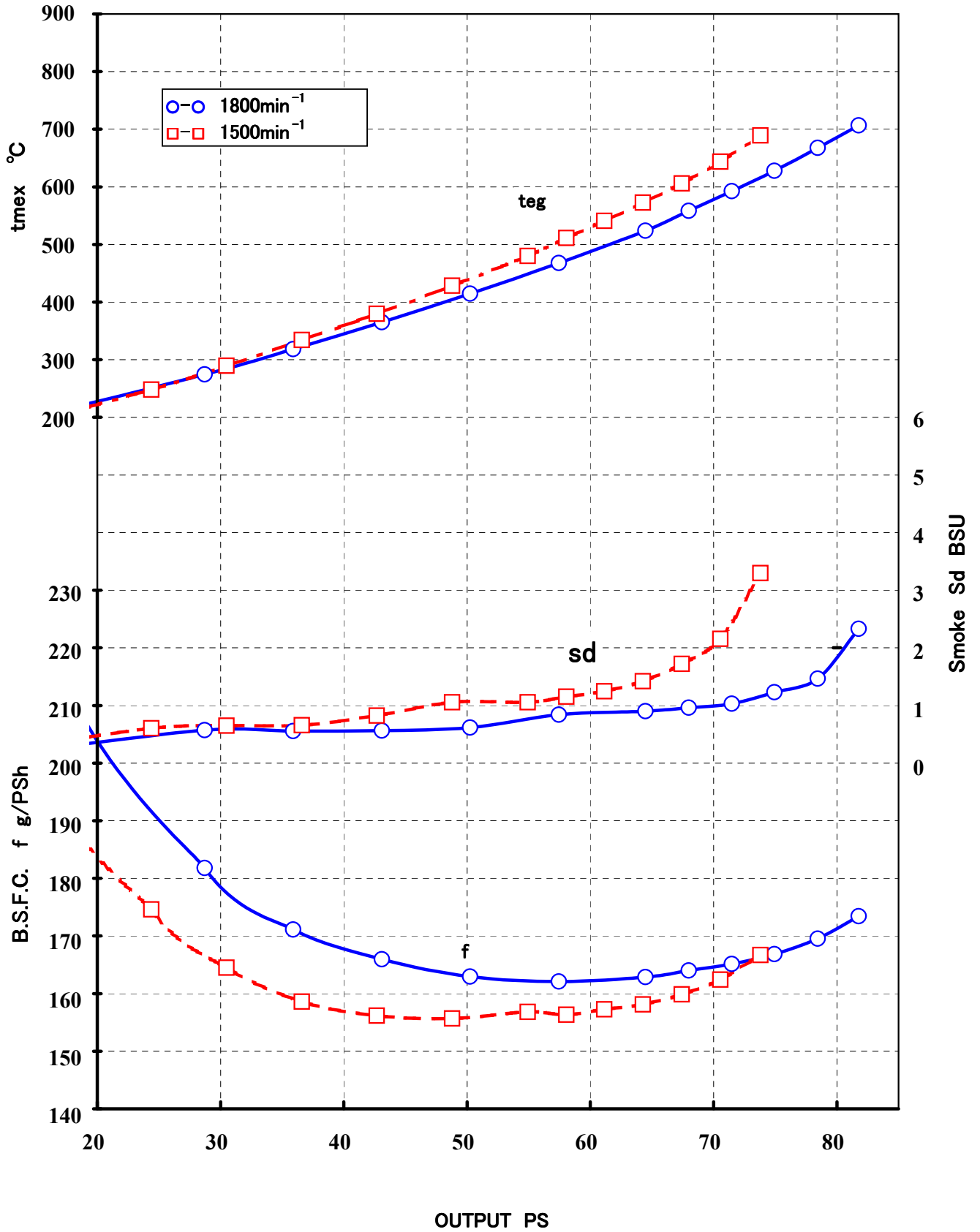

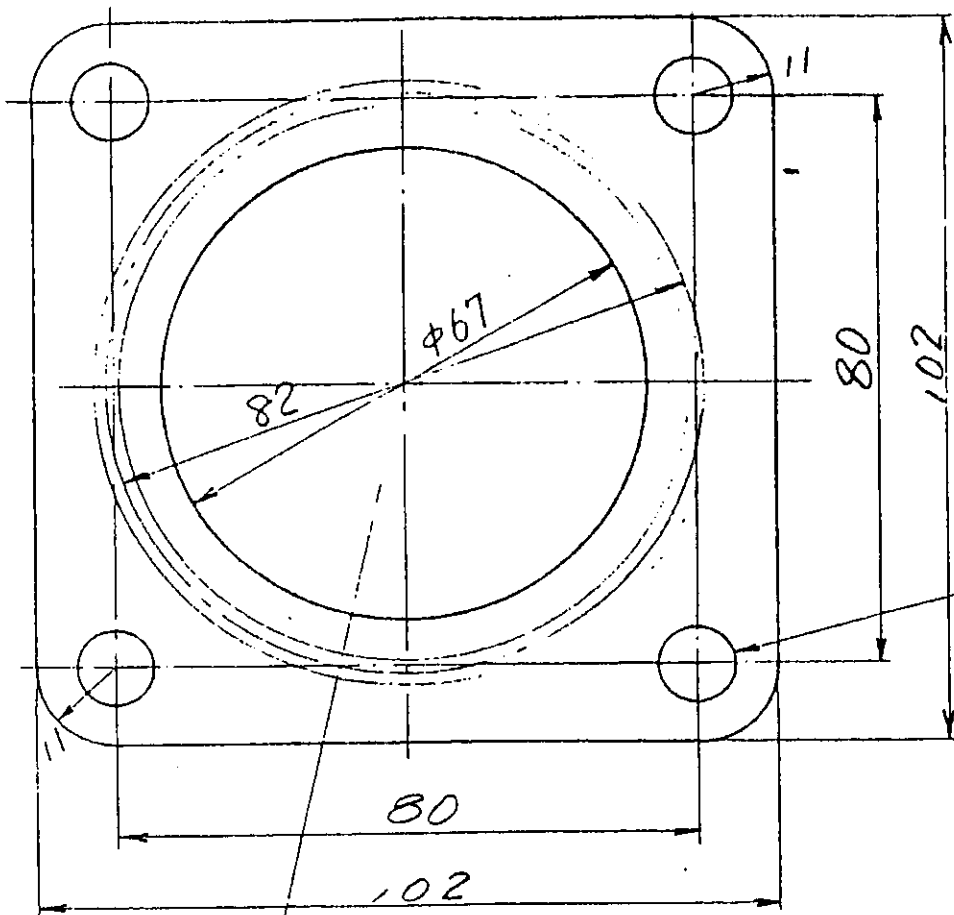

hole
4-11穴
M10ボルト
bolt

1
2
 $t=0.5$

ヤンマーディーゼル株式会社	
適用名称	
適用機種	Gasket, muffler
部品名称	ガスケット (EXH.)
部品コード	128300-13230

YANMAR DIESEL ENGINE CO., LTD.

3D-CAD

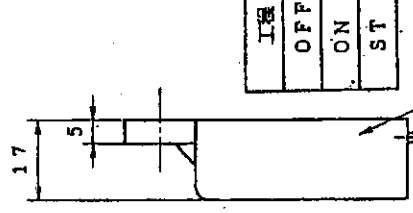
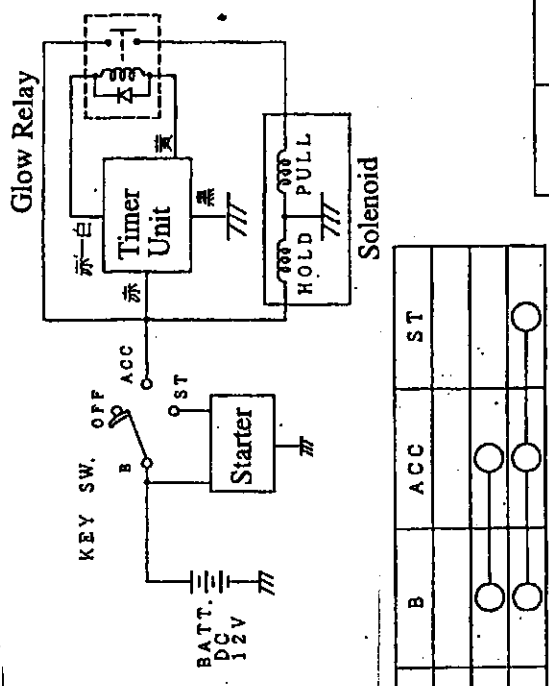

工程	B	ACC	ST
OFF	○	○	○
ON	○	○	○
ST	○	○	○

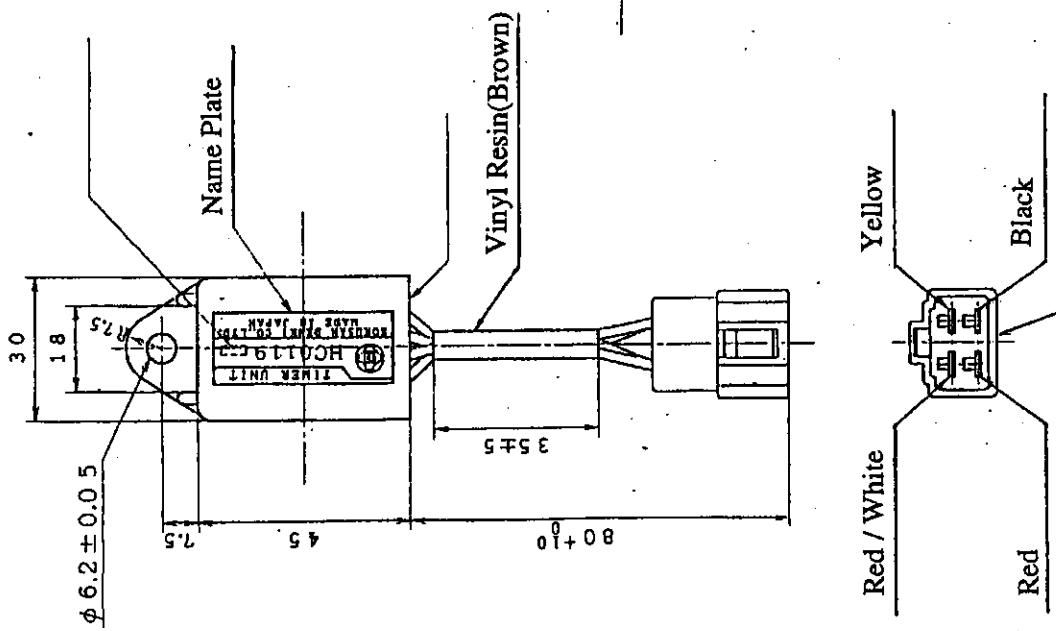

Connector : 7122-2446 (white)
(YAZAKI Company)

項目	動作シークエンス	
Key Switch	OFF	ON
Glow Relay	OFF	ON OFF
Solenoid Pull	OFF	ON OFF
Solenoid Hold	OFF	ON OFF
Starter	OFF	ON

1.0±0.5秒

TIMER (1sec)
タイマー (1sec)

YANMAR
ENGINE PRODUCT OPERATIONS DIV., YANMAR CO., LTD.
CODE 129211-77920

仕様

1. リレーON時間 : 15±3 (sec.)
2. 使用温度範囲 : -25°C~+80°C
3. 保存温度範囲 : -25°C~+80°C
4. 使用電源電圧範囲 : 8V~15V
5. 適用リレー仕様 : 12V 励磁電流 : 1 A
6. 耐水性 : 清水中10cmノ所ニ24時間保持シタ後、水分ヲ拭キ取り自然乾燥後、性能ニ異常ナキコト。但シ、カブラ及ビコネクタ部分ハ海水ガ無いヨウニ行ウコト。
7. 耐振性 : 20G一定ニテ100~1000Hz60secスイープニテX, Y, Z方向各2HR振動ヲ与工性能ニ異常ナキコト。但シ、ワイヤハハーネスハ共振ナキヨウ取リ付ケルコト。
8. 耐久性 : 30000サイクル動作サセタ後性能ニ異常ナキコト。

SPECIFICATIONS

1. OPERATION TIME : ON AFTER 15 sec.
2. USABLE TEMPERATURE RANGE : -25°C~+80°C
3. PRESERVE TEMPERATURE RANGE : -25°C~+80°C
4. USABLE VOLTAGE RANGE: 8V~15V
5. APPLICABLE RELAY : 12V
6. WATERPROOFING : DO NOT EXPOSED TO THE RAIN ON CONNECTOR AND TERMINAL
7. VIBRATION RESISTANCE : 20G
8. DUABILITY : 30000 cycle

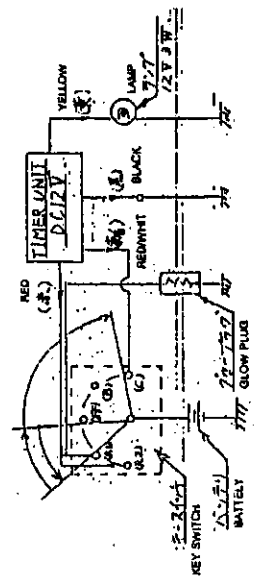
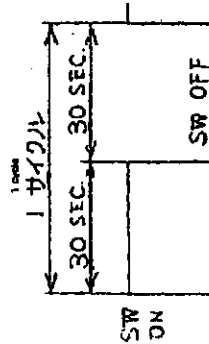
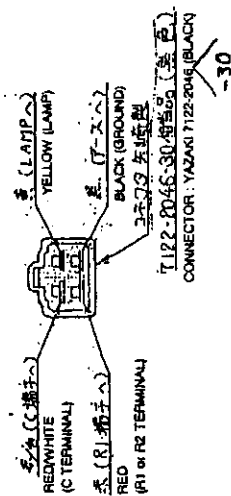
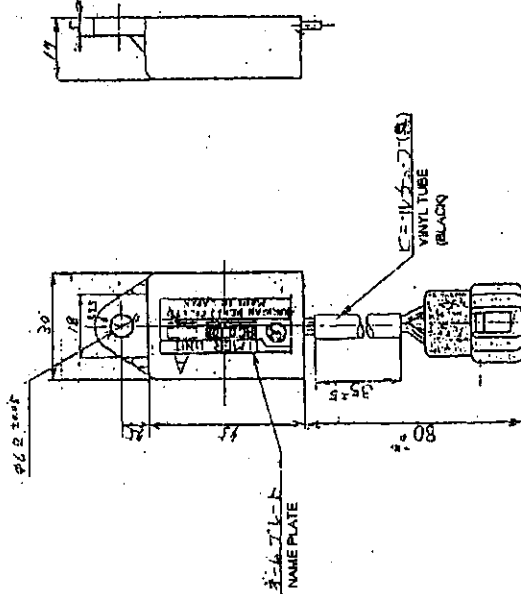

結城日
WIRING
DAIGUN

MODEL	TNE SERIESE
部品名称	ランプタイマ
NAME	TIMER, GLOW PLUG
PART No.	128300-77920

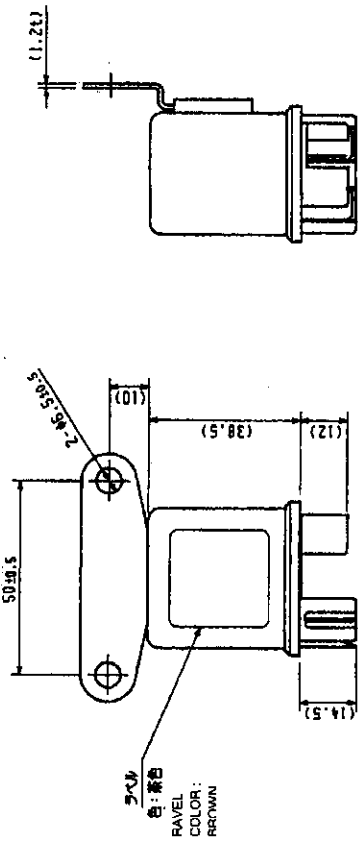

- 仕様
1. 定格電圧 : DC12V
 2. 連続定格 : 10 MIN.
 3. コイル抵抗値 : 37Ω
 4. インダクタンス : 66mH (at 1kHz)

SPECIFICATIONS

1. RATED VOLTAGE : DC12V
2. MAXIMUM OPERATING TIME : 10 MIN.
3. COIL RESISTANCE : 37 ohm
4. INDUCTANCE : 66mH (at 1kHz)

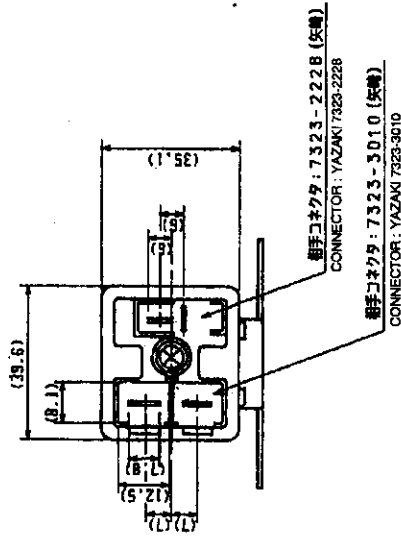

YANMAR DIESEL ENGINE CO., LTD.
ENGINE DEVELOPMENT DEPT.

MODEL	TNE SERIESE
部品名称	グローリレー
NAME	GLOW RELAY
PART No.	119650-77910

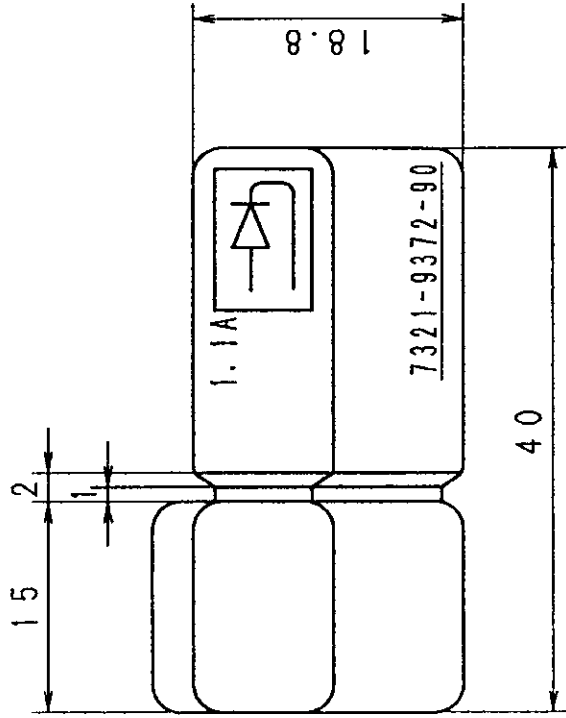
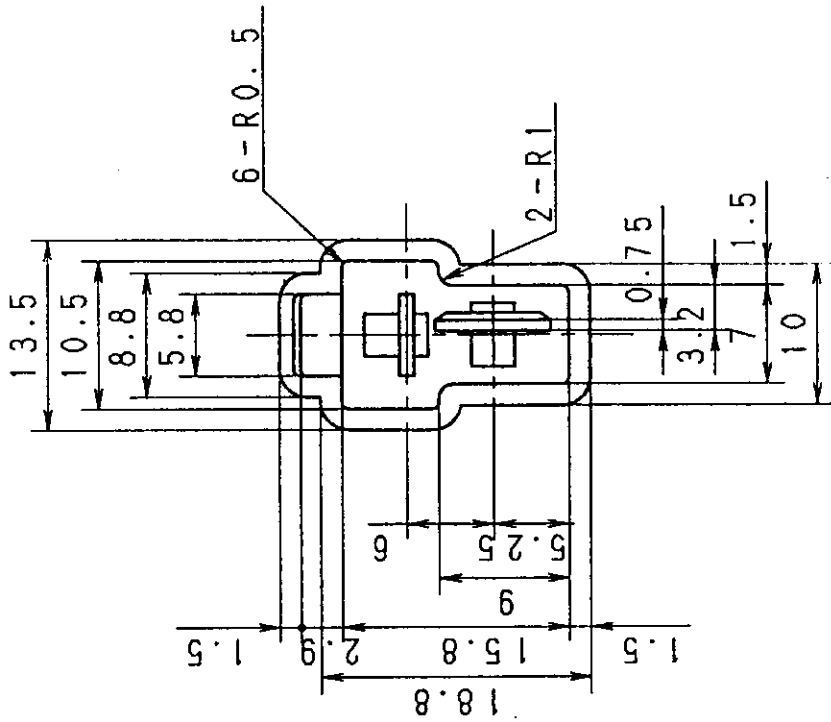

Mate coupler : 7123-2228
 Mate terminal : 7116-2090

DIODE

DWG. NO. _____

YANMAR DIESEL ENGINE CO., LTD. 119643-66900

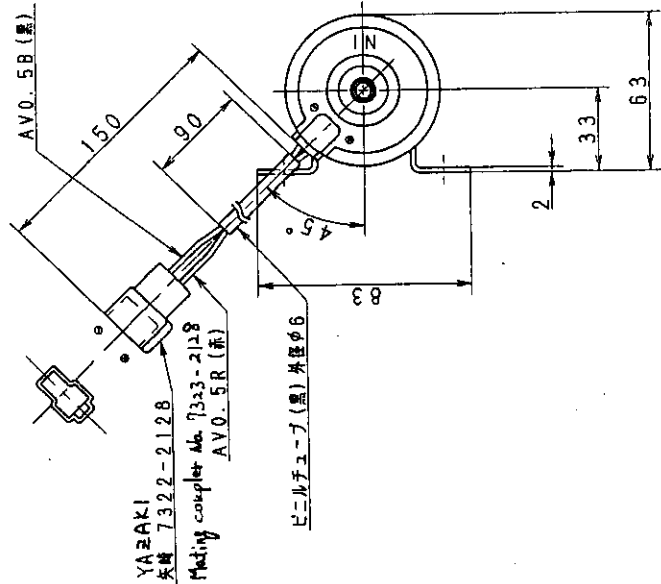

SPECIFICATIONS
 (ROOM TEMPERATURE CHARACTERISTIC,
 MEASUREMENT METHOD AND EQUIPMENT
 ARE BASED ON JIS D3606)

1. RATED VOLTAGE: 12V DC
2. OPERATING VOLTAGE RANGE: 8.5-15.5V
3. OPERATING CURRENT: MAX 1.5A
4. DELIVERY: MIN 400cc/min AT FREE FLOW (0.1kgf/cm² TOTAL PRESSURE)
5. TOTAL PRESSURE (DELIVERY + SUCTION)
 : MAX 0.38kgf/cm² AT ZERO DELIVERY
 : MAX -30mmHg
7. AIR TIGHTNESS: SHOULD HAVE NO LEAKAGE UNDER A PRESSURE OF 1kgf/cm² APPLIED TO INLET AND OUTLET FOR 15 SECONDS
8. OPERATING TEMP. RANGE: -30-70°C
9. TEST FUEL: JIS K2203 OR K2201
10. FIXING DIRECTION FOR TEST: INLET & OUTLET PIPES HORIZONTALLY
11. WEIGHT: 600g
12. SURFACE TREATMENT: SEE BELOW
13. FUEL TIGHTNESS OF CHECK VALVE
 THE AMOUNT OF LEAK TO OUT SIDE SHALL BE MAX 5cc/min WHEN PRESSURIZED 0.06kgf/cm² FROM IN PORT WITH GASOLINE

14. VIBRATION: JIS D1601 5.3(1) STEP4
15. WATER PROOF: JIS D0203 O1
 SHOULD BE NO WATER INSIDE OF PUMP
16. THERMAL SHOCK:
 a) PATTERN: SEE FIG 1
 b) CYCLES: 4
17. THERMAL RESISTANCE:
 PATTERN: 70°C at 240hrs AND -20°C 240hrs
18. HIGH TEMP. PERFORMANCE:
 a) VOLTAGE: 14V DC
 b) FUEL TEMP.: 50°C
 c) ENVIRONMENT TEMP.: 70°C
 d) OPERATING TIME: 96hrs
19. FALLING TOUGHNESS:
 FALL FROM 300mm HEIGHT TO THE CONCRETE
20. SURGE VOLTAGE: JASO D001-A-1.2 B-1.2 ALL
21. REVERSALY VOLTAGE APPLYING:
 JASO D001-A-2, 13V FOR 1min
22. DURABILITY TEST: AFTER TEST AS FOLLOWS, DROP OF DELIVERY SHOULD BE LESS THAN 10%
 a) VOLTAGE: 14V
 b) THERMAL ENVIRONMENT: ROOM TEMPERATURE
 c) OPERATING TIME: 1000hrs

AFTER EACH TEST (NO. 14-24) AS FOLLOWS,
 PUMP MUST OPERATE NORMALLY

23. DRY PUMPING DURABILITY:
 a) VOLTAGE: 14V DC
 b) PATTERN: 5min ON-OFF
 c) CYCLES: 10
24. WATER PROOF DURABILITY TEST
 a) OPERATING IN THE AIR: 1hr
 b) STOPPING IN THE WATER: 1hr
 c) CYCLES: 350

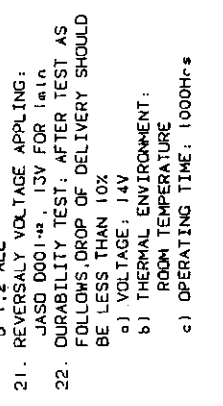

NOTES FOR OPERATING FUEL PUMP

1. USE A (60 MESH FILTER(PAPER TYPE)) BETWEEN PUMP AND FUEL TANK
2. FIX A PUMP INLET & OUTLET PIPES HORIZONTALLY OR VERTICALLY (OUTLET IS UP SIDE)
3. PUT A CLIP AT HOSE INSERTING PLACE
4. DON'T OPERATE WITHOUT FUEL



70°C
 Run Temp 常温
 -30°C
 5 min
 2 h
 2 h
 2 h
 5 min

YANMAR DIESEL	
PARTS NAME	FUEL FEED PUMP
PARTS CODE	119225-52102