

YC16VC3300-D31

Prime power: 2205 kW @ 1500 r/min

Standby power: 2426 kW @ 1500 r/min

Emission regulations to be observed:

GB 20891-2014 Stage III

Introduction

YC12VC series engine developed independently by Yuchai is a classic product. It is characterized by energy-saving and environment-friendly, excellent performance, compact structure, and reliability and durability; the indexes, such as pollutant emission, dynamic performance, economy, and reliability, reach the international advanced level.

Product Features

- ◆ Electronic unit pump, four-valve structure, high-efficiency turbocharged & intercooled, and Yuchai combustor technologies are adopted for realizing low fuel consumption, less emission, outstanding speed governing performance, and fast and high-quality loading.
- ◆ High-strength material, reinforced grid structure with cambered surface, and 4-bolt main bearing structure are adopted for the engine body; thus the engine body is characterized by high stiffness, slight vibration, and lower noise.
- ◆ The crankshaft is made of high-quality alloy steel by using all fiber extrusion forging process, and the journal and circular bead are subject to quenching heat treatment for improving wear resistance and prolonging service life.
- ◆ The world-class equipment and technologies are used for production; thus, the quality of such model is stable and reliable.

Version No.: 2017V01 Implemented on: 2017-09-01

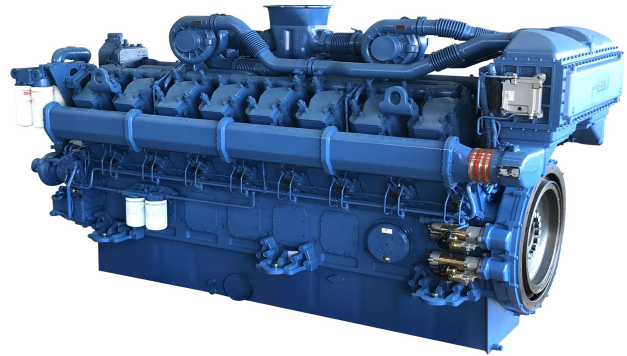

(Image shown may not reflect actual engine)

- ◆ The structure of one head for one cylinder is adopted; maintenance window is set at the side of the engine body, which ensures easy maintenance.
- ◆ G3 performance requirements for generator set are met.

Product Service

- ◆ Service: Yuchai has built the largest service network in the industry with the minimum service radius, the most extensive “three guarantees” and the shortest response time. 49 global offices are set up, including 14 overseas offices in Europe, Africa and South America etc. Besides, 108 overseas service agents, more than 3,000 service stations and 5,000 sales networks of fittings are established, providing the users with satisfying and considerate services.
- ◆ 24h global service hotline: +86 95098.

Engine speed	Application	Standard generator unit output		Engine power			
				Total power		Net power	
r/min		kVA	kW	kW	Ps	kW	Ps
1500	Prime	2500	2000	2205	2999	2205	2999
	Standby	2750	2200	2426	3299	2426	3299

Notes:

1. Prime Power: which corresponds to the basic power (PRP) described in ISO 8528. Implement the maintenance according to the Yuchai's requirement, maximum power of variable load continuous output unlimited time. The average output power shall not exceed 70% of the prime power in every 24 hours of operation.
Standby Power: In correspondence with the emergency standby power (ESP) stated in ISO 8528. Implement the maintenance according to the Yuchai's requirement, maximum power at a variable load in the event of a main power network failure up to a maximum of 200 hours per year. The average output power shall not exceed 70% of the standby power in every 24 hours of operation.
2. The engine power data stated in the table is the measured performance under the condition stated in ISO 8528-1 and ISO 3046.
3. The power output of the generator unit is calculated according to the efficiency of the AC generator. Thus, it is for reference only.
4. The kVA and kW values are converted as per standard power factor 0.8.
5. The information mentioned above is the latest one, however, the relevant information may be altered after publication.

Engine load	1500 r/min	
	g/ (kW h)	L/h
Standby power	213.5	620.3
Prime power	205.7	543.2
75% prime power	202.5	401.1
50% prime power	209.8	277.0

Remarks: the diesel oil density is 0.835 kg/L.

Technical Data

Type	Vertical, V-type, water-cooled, four-stroke
Induction system	Turbocharged & Intercooled
Type of combustion chamber	Direct-injection reentrant ω combustion chamber
Cylinder quantity - Bore x stroke.	16-200×210mm
Number of valve per cylinder.	4
Displacement	105.56
Compression ratio	13.5:1
Cylinder type	Wet-type cylinder sleeve
Working sequence	left 1—right 1-left 6—right 6-left 2—right 2-left 5—right 5-left 8—right 8-left 3-right 3-left 7-right 7-left 4-right 4
Fuel supply system	Electronic unit pump
Lubrication mode	Combination of pressure and splashing
Starting mode	Electronic
Engine oil capacity	430L (dry-type engine)
Rotation	Anticlockwise (facing the power delivery end)
Minimum no-load speed.	(600~650) r/min
Speed-regulation grade	ISO 8528 G3
Total dry weight	
Engine	11400kg
Radiator	2600kg

The final weight and sizes of the engine varies according to the specific arrangement.

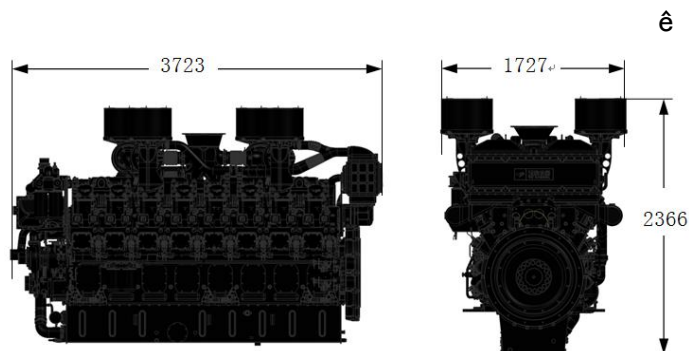

Engine Arrangement

➤ Air Intake System

- Air filter
- Turbocharger

➤ Cooling system

- Intercooler
- Oil cooler
- Radiator (optional)

➤ Electrical device

- 24 V electric system

➤ Fuel system

- Electronic unit pump
- Fuel Filter
- Mechanical oil delivery pump

➤ Lubrication system

- Engine oil filter

➤ Flywheel and flywheel housing

- SAE 21" flywheel
- SAE 00# flywheel housing

➤ Documents

- Operation Instruction
- Installation Guide
- Parts catalog

Fuel grade: Summer: 0# and 10# ordinary diesel oil of GB 252 - 2015 premium grade or first grade; Winter: 0#, -10#, -20# and -35# ordinary diesel oil of GB 252 - 2015 premium grade or first grade
 Oil brand: 15W-40 in summer; 10W-30 or other environmentally suitable diesel engine oils with the quality grade not lower than Grade CH-4 as provided in GB 11122-2006 in winter.