

YC6TD840-D31

Version No.: 2017V01 Implemented on: 2017-09-01

Prime power: 561kW @ 1500 r/min

Standby power: 616 kW @ 1500 r/min

Emission regulations to be observed:

GB 20891-2014 Stage III

Introduction

YC6TD series engine is a classic engine product developed by Yuchai, which is well-known and highly recognized in the market and has market holdings of more than 400,000 sets. YC6TD840-D31 engines for generator sets, developed based on YC6TD engines, have advantages such as high reliability, durability, energy-saving and environment-friendly, compact structure, strong transient loading capacity and easy maintenance.

Product Features

- ◆ The main structures, such as engine body, are time-tested, which ensures the high reliability of the whole engine.
- ◆ Advanced and mature electronic unit pump and high-efficiency turbocharged & intercooled technologies are adopted, which ensure precise control of fuel-injection quantity and sufficient air intake; and the full combustion, low fuel consumption and less emission of diesel engine under different load conditions are ensured.
- ◆ Full-flow oil cooler is adopted; thus heat dissipation efficiency is increased by 30% and oil temperature is effectively reduced; and the oil can lubricate the parts under reasonable temperature to reduce the friction loss.

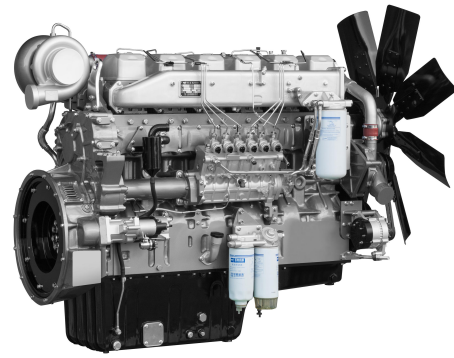

(Image shown may not reflect actual engine)

- ◆ The structure of one head for one cylinder is adopted, which ensures easy maintenance and reliable sealing.
- ◆ The internal cooling oil passage technology is adopted for piston, which effectively reduces piston temperature and ensures the long service life.
- ◆ G3 performance requirements for generator set are met.

Product Service

- ◆ Service: Yuchai has built the largest service network in the industry with the minimum service radius, the most extensive “three guarantees” and the shortest response time. 49 global offices are set up, including 14 overseas offices in Europe, Africa and South America etc. Besides, 108 overseas service agents, more than 3,000 service stations and 5,000 sales networks of fittings are established, providing the users with satisfying and considerate services.
- ◆ 24h global service hotline: +86 95098.

Engine speed	Application	Standard generator unit output		Engine power			
				Total power		Net power	
r/min		kVA	kW	kW	Ps	kW	Ps
1500	Prime	625	500	561	763	546	743
	Standby	688	550	616	838	601	817

Notes:

1. Prime Power: which corresponds to the basic power (PRP) described in ISO 8528. Implement the maintenance according to the Yuchai's requirement, maximum power of variable load continuous output unlimited time. The average output power shall not exceed 70% of the prime power in every 24 hours of operation.
Standby Power: In correspondence with the emergency standby power (ESP) stated in ISO 8528. Implement the maintenance according to the Yuchai's requirement, maximum power at a variable load in the event of a main power network failure up to a maximum of 200 hours per year. The average output power shall not exceed 70% of the standby power in every 24 hours of operation.
2. The engine power data stated in the table is the measured performance under the condition stated in ISO 8528-1 and ISO 3046.
3. The power output of the generator unit is calculated according to the efficiency of the AC generator. Thus, it is for reference only.
4. The kVA and kW values are converted as per standard power factor 0.8.
5. The information mentioned above is the latest one, however, the relevant information may be altered after publication.

Engine load	1500 r/min	
	g/ (kW h)	L/h
Standby power	221.6	163.5
Prime power	214.9	144.4
75% prime power	207.2	104.4
50% prime power	214.4	72.0

Remarks: the diesel oil density is 0.835kg/L.

Technical Data

Type	Vertical, in-line, water-cooled, four-stroke
Induction system	Turbocharged & Intercooled
Type of combustion chamber	Direct-injection reentrant combustion chamber
Cylinder quantity - Bore x stroke.	6-152×180mm
Number of valve per cylinder.	4
Displacement	19.6L
Compression ratio	14:1
Cylinder type	Wet-type cylinder sleeve
Working sequence	1-5-3-6-2-4
Fuel supply system	Electronic unit pump
Lubrication mode	Combination of pressure and splashing
Starting mode	Electronic
Engine oil capacity	55L (dry-type engine)
Engine oil and fuel consumption ratio	≤0.1
Rotation	Anticlockwise (facing the power delivery end)
Minimum no-load speed.	(600~650) r/min
Speed-regulation grade	ISO 8528 G3
Noise L_p	≤100 dB(A)
Total dry weight	
Engine	2250kg
Radiator	380kg

The final weight and sizes of the engine varies according to the specific arrangement.

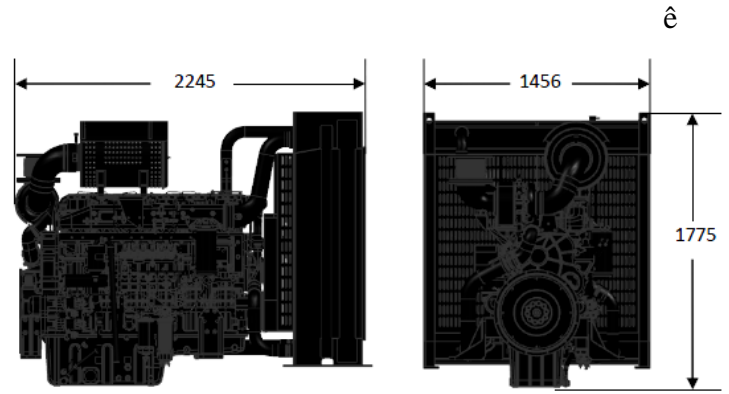

Engine Arrangement

➤ Air Intake System

Air filter

➤ Cooling system

Radiator (optional)

➤ Electrical device

24 V electric system

Inlet pre-heater (optional)

➤ Fuel system

Electronic unit pump system

Fuel Filter (two-stage diesel filter)

➤ Lubrication system

Engine oil filter

➤ Flywheel and flywheel housing

SAE 14" flywheel

SAE 1# flywheel housing

➤ Documents

Operation Instruction

Installation Guide

Parts catalog

Fuel grade: Summer: 0# and 10# ordinary diesel oil of GB 252-2015 premium grade or first grade. Winter: 0#, -10#, -20#, and -35# ordinary diesel oil of GB 252-2015 premium grade or first grade.

Oil brand: 15W-40 in summer; 10W-30 or other environmentally suitable diesel engine oils with the quality grade not lower than Grade CH-4 as provided in GB 11122-2006 in winter.